



SERVICE MANUAL

HF TRANSCEIVER

IC-77

INTRODUCTION

This service manual describes the latest service information for the **IC-77** HF TRANSCEIVER at the time of publication.

VERSION NO.	VERSION	SYMBOL
#01	Philippines	PHI
#02	Other	OTH

To upgrade quality, all electrical or mechanical parts and internal circuits are subject to change without notice or obligation.

DANGER

NEVER connect the transceiver to an AC outlet or to a DC power supply that uses more than 16 V. This will ruin the transceiver.

DO NOT expose the transceiver to rain, snow or any liquids.

DO NOT reverse the polarities of the power supply when connecting the transceiver.

DO NOT apply an RF signal of more than 20 dBm (100 mW) to the antenna connector. This could damage the transceiver's front end.



ORDERING PARTS

Be sure to include the following four points when ordering replacement parts:

1. 10-digit order numbers
2. Component part number and name
3. Equipment model name and unit name
4. Quantity required

<SAMPLE ORDER>

1120000970 IC M54562P IC-77 MAIN UNIT 5 pieces
8810000230 Screw PH M3 x 6 IC-77 Chassis 10 pieces

Addresses are provided on the inside back cover for your convenience.

REPAIR NOTES

1. Make sure a problem is internal before disassembling the transceiver.
2. **DO NOT** open the transceiver until the transceiver is disconnected from its power source.
3. **DO NOT** force any of the variable components. Turn them slowly and smoothly.
4. **DO NOT** short any circuits or electronic parts. An insulated tuning tool **MUST** be used for all adjustments.
5. **DO NOT** keep power ON for a long time when the transceiver is defective.
6. **DO NOT** transmit power into a signal generator or a sweep generator.
7. **ALWAYS** connect a 50 dB to 60 dB attenuator between the transceiver and a deviation meter or spectrum analyzer when using such test equipment.
8. **READ** the instructions of test equipment thoroughly before connecting equipment to the transceiver.

TABLE OF CONTENTS

SECTION 1	SPECIFICATIONS	1 - 1
SECTION 2	DISASSEMBLY INSTRUCTIONS	2 - 1
SECTION 3	INSIDE VIEWS	3 - 1
SECTION 4	CIRCUIT DESCRIPTION	4 - 1 to 8
4 - 1	RECEIVER CIRCUITS	4 - 1
4 - 2	TRANSMITTER CIRCUITS	4 - 4
4 - 3	PLL CIRCUITS	4 - 6
4 - 4	LOGIC CIRCUITS	4 - 7
4 - 5	REGULATOR CIRCUITS	4 - 8
SECTION 5	ADJUSTMENT PROCEDURES	5 - 1 to 9
5 - 1	PREPARATION BEFORE SERVICING	5 - 1
5 - 2	PLL ADJUSTMENT	5 - 2
5 - 3	RECEIVER ADJUSTMENT	5 - 2
5 - 4	TRANSMITTER ADJUSTMENT	5 - 6
SECTION 6	PARTS LIST	6 - 1 to 14
SECTION 7	MECHANICAL PARTS	7 - 1 to 4
7 - 1	FRONT, CABINET PARTS AND ACCESSORIES	7 - 1
7 - 2	CHASSIS PARTS	7 - 3
SECTION 8	BOARD LAYOUTS	8 - 1 to 6
8 - 1	MAIN UNIT	8 - 1
8 - 2	FRONT, VR AND JACK UNITS	8 - 3
8 - 3	PLL UNIT	8 - 5
8 - 4	PA UNIT	8 - 6
8 - 5	FILTER UNIT	8 - 6
SECTION 9	BLOCK DIAGRAM	9 - 1
SECTION 10	VOLTAGE DIAGRAMS	10 - 1 to 2
10 - 1	MAIN, PA AND FILTER UNITS	10 - 1
10 - 2	PLL AND FRONT UNITS	10 - 2

SECTION 1 SPECIFICATIONS

GENERAL

- Frequency coverage : Transmit 1.6050-1.9999 MHz 3.5000-3.9999 MHz
5.0000-7.9999 MHz 9.0000-28.0000 MHz
28.0000-30.0000 MHz (Except Philippines version)
Receive 0.5000-30.0000 MHz
- Mode : Philippines version SSB (USB)
Other versions Normal setting SSB (USB)
Optional settings SSB (LSB), AM, CW
- Number of channels : 50
- Antenna impedance : 50 Ω (nominal)
- Usable temperature range : -10°C to $+60^{\circ}\text{C}$ ($+14^{\circ}\text{F}$ to $+140^{\circ}\text{F}$)
- Power supply requirement : 13.8 V DC $\pm 15\%$ (negative ground)
- Current drain (at 13.8 V) : Transmit Max. 20 A
Receive Squelched 1.3 A
Max. audio output 2.1 A
- Frequency stability : Philippines version Less than ± 20 Hz from 15 min. after power ON at 0°C to $+50^{\circ}\text{C}$
Other versions Less than ± 200 Hz from 1 min. to 60 min. after power ON
Less than ± 30 Hz/hr. after 1 hr. at $+25^{\circ}\text{C}$
Less than ± 350 Hz with temperature fluctuations of 0°C to $+50^{\circ}\text{C}$
- Dimensions : 240 (W) \times 95 (H) \times 239 (D) mm
9.4 (W) \times 3.7 (H) \times 9.4 (D) in
(Projections not included)
- Weight : 3.9 kg (8.6 lb)

TRANSMITTER

- Output power : SSB, CW 5-100 W
AM 5-25 W
(continuously adjustable)
- Modulation system : USB, LSB Balanced modulation
AM Low power modulation
- Spurious emissions : Less than -46 dB
- Carrier suppression : More than 40 dB
- Unwanted sideband suppression : More than 50 dB
- Microphone impedance : 600 Ω

RECEIVER

- Sensitivity (Preamp ON) : USB, LSB, CW (12 dB SINAD) 1.6050-30.0000 MHz Less than 0.5 μV
AM (10 dB S/N) 0.5000-1.6049 MHz Less than 12.6 μV
1.6050-30.0000 MHz Less than 2.0 μV
- Squelch sensitivity (Preamp OFF) : SSB, CW 5.6 μV
- Selectivity : USB, LSB, CW More than 2.1 kHz/ -6 dB Less than 4.0 kHz/ -60 dB
AM More than 6.0 kHz/ -6 dB Less than 20.0 kHz/ -40 dB
- Spurious and image rejection ratio : More than 70 dB
- Audio output power : More than 2.6 W with an 8 Ω load
- RIT variable range : ± 1.2 kHz

All stated specifications are subject to change without notice or obligation.

SECTION 2 DISASSEMBLY INSTRUCTIONS

1. Remove 12 screws from the top and bottom covers.

2. Remove 11 screws from the PA unit cover.

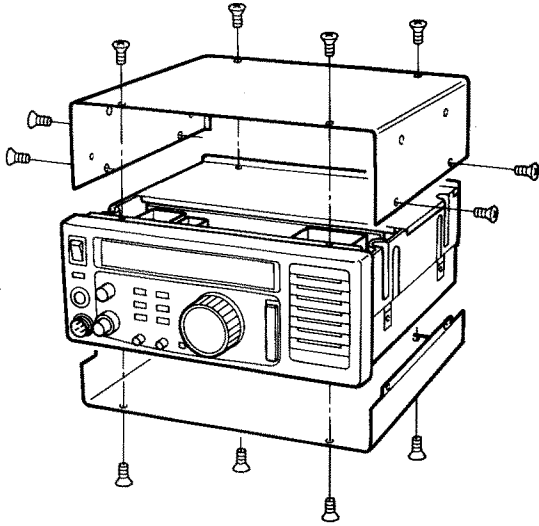

Fig. 1

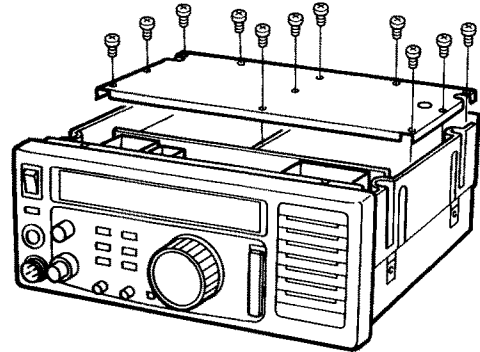

Fig. 2

To remove the front panel:

1. Unplug 8 connectors as shown in Fig. 4 and 5.
2. Remove 4 screws as shown in Fig. 3.
3. Unplug lead cable from [POWER] switch.
4. Remove 1 screw from J10 as shown in Fig. 3.

Remove flat cables.

- ① Pull out the connector tab.
- ② Remove the flat cable.

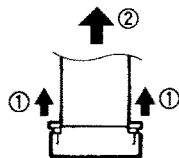

[POWER] switch

1-pin, from PA unit, W23

J10

Earth terminal, from MAIN unit, EP12

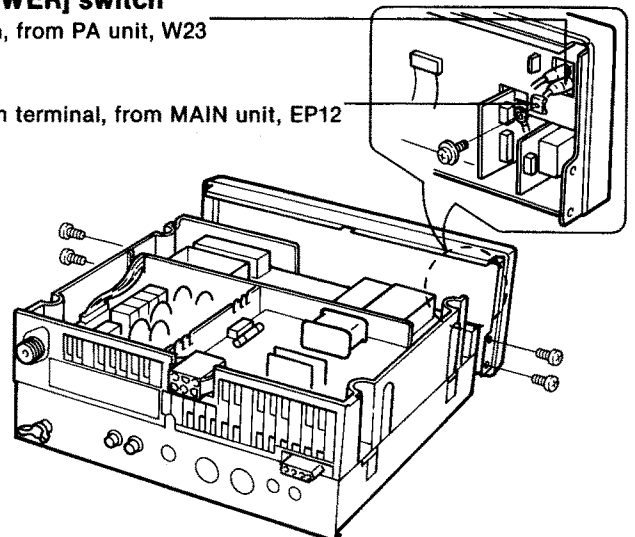

Fig. 3

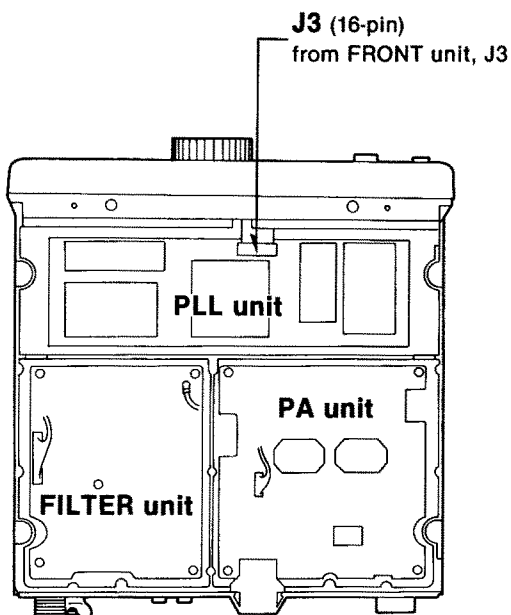

Fig. 4

J9 (16-pin)
from FRONT unit, J1

J10 (16-pin)
from FRONT unit, J2

J11 (4-pin)
from FRONT unit, P2

J15 (4-pin)
from JACK unit, P1

J16 (3-pin)
from Speaker (SP1), P1

J12 (16-pin)
from VR unit, P2

J7 (5-pin)
from FRONT unit, P3

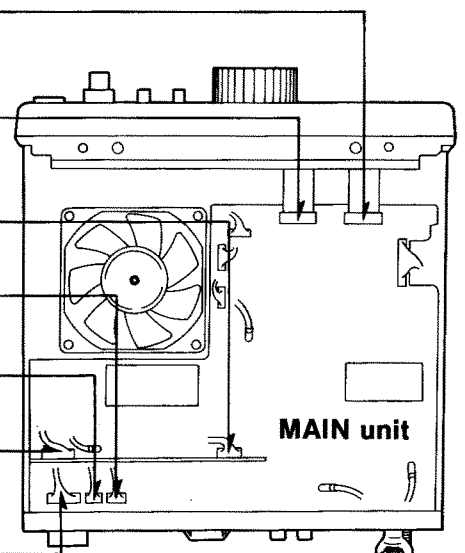
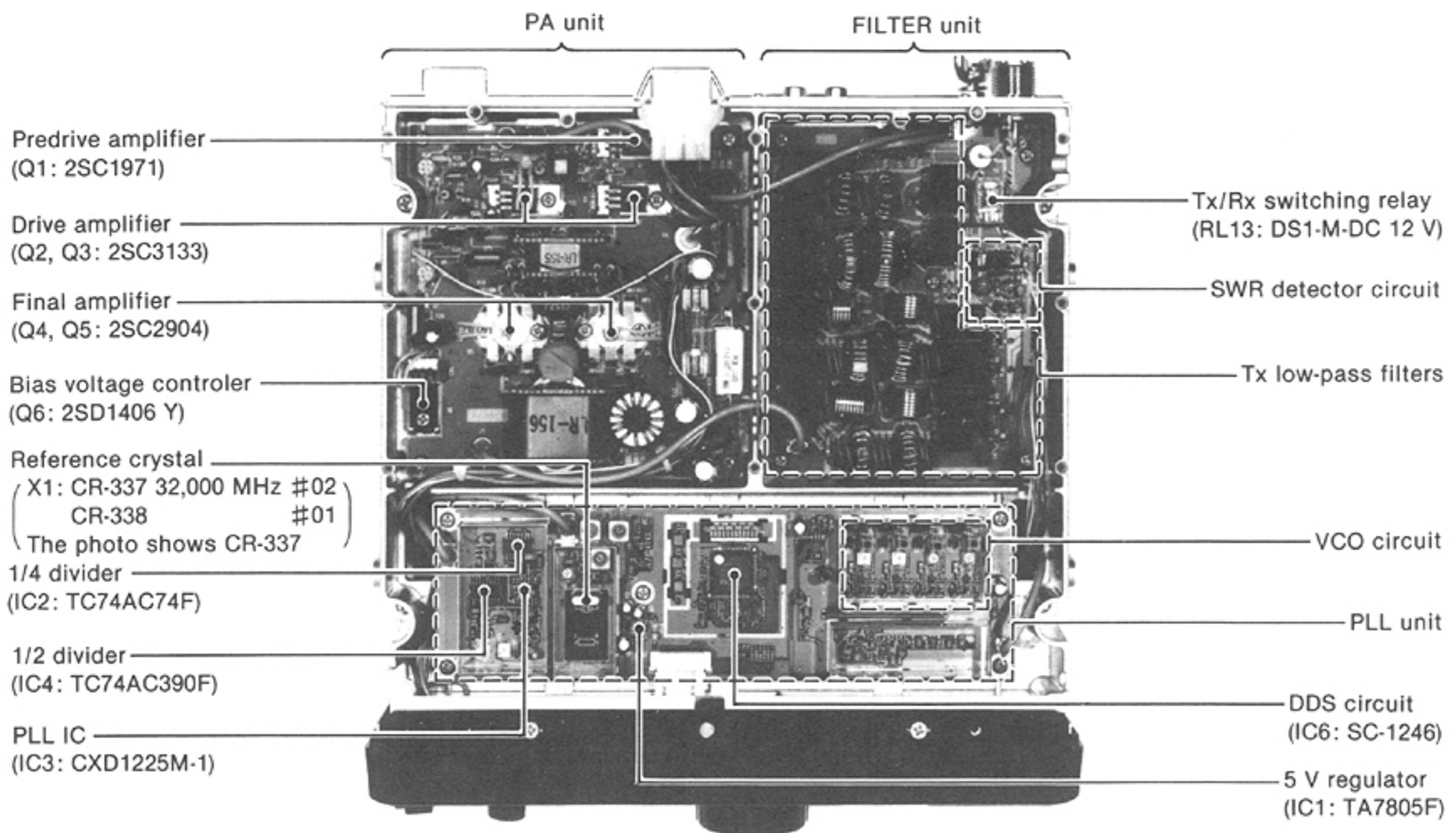

Fig. 5

SECTION 3 INSIDE VIEWS

• PLL, PA AND FILTER UNITS



• MAIN UNIT

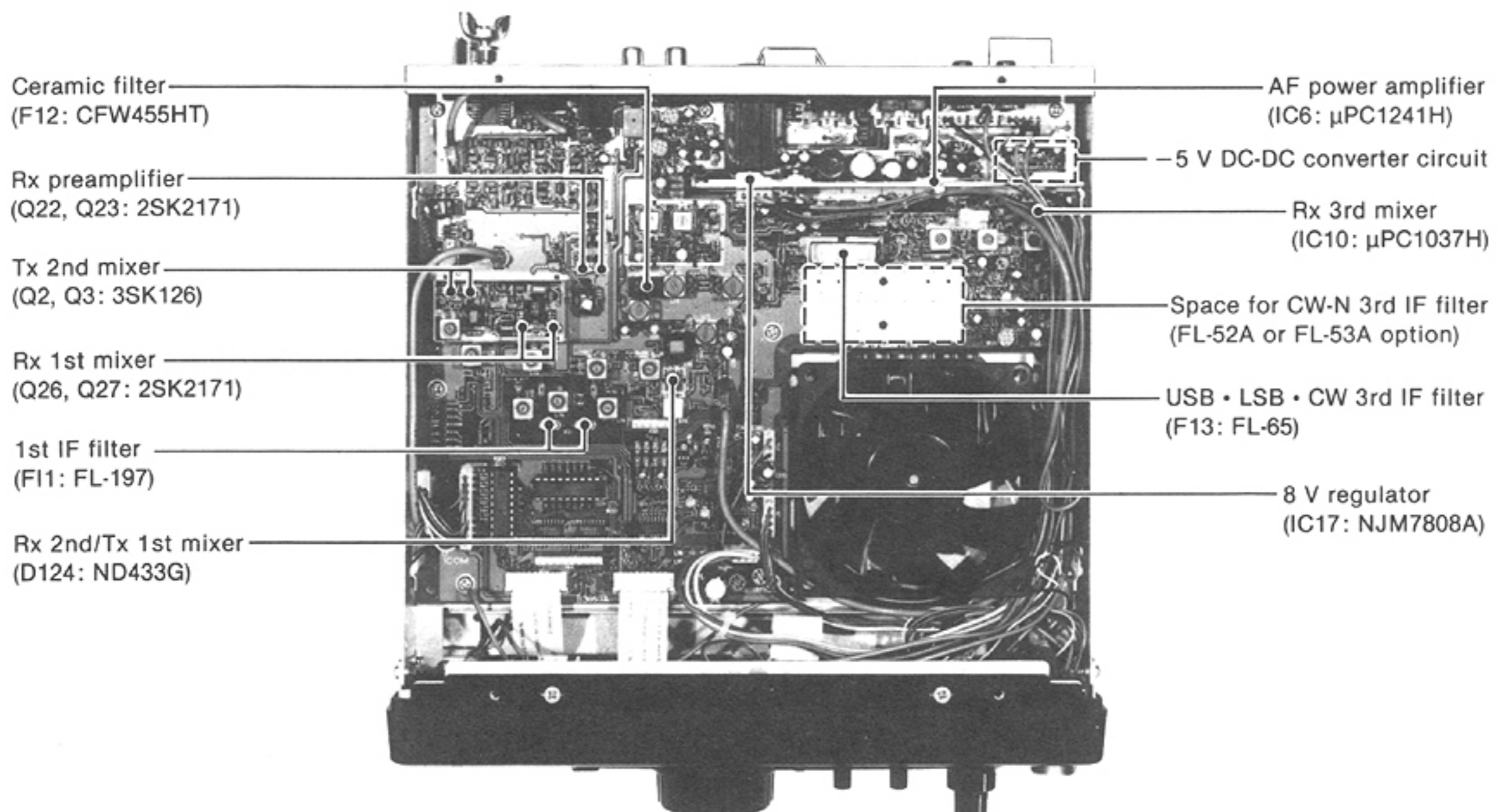

SECTION 4 CIRCUIT DESCRIPTION

4-1 RECEIVER CIRCUITS

4-1-1 RF SWITCHING CIRCUIT (FILTER AND MAIN UNITS)

The RF switching circuit leads receive signals to bandpass filters from the antenna connector while receiving. While transmitting, this circuit leads the signals from the RF power amplifier to the antenna connector. This circuit includes a 20 dB RF attenuator circuit to prevent distortion from very strong signals.

RF signals from the antenna connector pass through the transmit/receive switching relay (RL13) and low-pass filter (L14, C14–C16), and are then applied to the MAIN unit via P2 (MAIN unit: J2).

The signals from the FILTER unit are either bypassed or are attenuated at the 20 dB attenuator (R99, RL1). There are no non-linear components from the antenna connector to the attenuator in this circuit construction. Therefore the attenuator effectively prevents distortion caused by strong signals. The signals are then applied to RF filters.

4-1-2 RF BANDPASS FILTER CIRCUIT (MAIN UNIT)

RF bandpass filters pass only the desired band signals and suppress any undesired band signals.

The RF circuit has 7 RF bandpass filters (BPF) for signals above 1.6 MHz and 1 low-pass filter (LPF) for signals below 1.6 MHz. The signals pass through the low-pass or one of the bandpass filters depending on their frequencies.

(1) 0.5–1.6 MHz

These signals pass through a low-pass filter (L28, L29, C84–C86) to suppress unwanted frequencies. The filtered signals are bypassed a preamplifier by a BPF control signal (B0) and preamp switch (Q21), and are then applied to the 1st mixer circuit (Q26, Q27).

(2) 1.6–2.0 MHz

These signals pass through a bandpass filter (L35–L39, C92–C99) to suppress unwanted frequencies. The filtered signals are then applied to the preamplifier circuit.

(3) 2.0–30.0 MHz

These signals pass through a high-pass filter (L33, L34, C89, C90, C359, C367) to suppress strong signals below 1.6 MHz, such as from broadcasting stations. The filtered signals are applied to one of 6 bandpass filters depending on their frequencies and are then applied to the preamplifier circuit.

USED RF FILTER

BAND	CONTROL SIGNAL	ENTRANCE DIODE	BAND	CONTROL SIGNAL	ENTRANCE DIODE
0.5–1.6 MHz	$\overline{B0}$	D33	8–11 MHz	$\overline{B4}$	D45a
1.6–2 MHz	$\overline{B1}$	D38	11–15 MHz	$\overline{B5}$	D45b
2–4 MHz	$\overline{B2}$	D41a	15–22 MHz	$\overline{B6}$	D49a
4–8 MHz	$\overline{B3}$	D41b	22–30 MHz	$\overline{B7}$	D49b

4-1-3 PREAMPLIFIER CIRCUIT (MAIN UNIT)

The preamplifier circuit uses two 2SK2171s to obtain 10 dB of gain over a wideband frequency range. When the preamplifier is turned ON, the signals above 1.6 MHz are applied to the preamplifier circuit.

Q22 and Q23 are connected in parallel to easily match the impedance to 50 Ω . Q24 and Q25 switch the signals from a bandpass filter, either to be bypassed, or to be applied to the preamplifier, depending on the [PREAMP] switch condition.

Amplified or bypassed signals are applied to the 1st mixer circuit (Q26, Q27).

4-1-4 1ST MIXER CIRCUIT (MAIN UNIT)

The 1st mixer circuit mixes the receive signals with the 1st LO signal to convert the receive signal frequencies to a 64.455 MHz 1st IF.

The signals from the preamplifier circuit, or signals which bypass the preamplifier, pass through a low-pass filter. This low-pass filter suppresses signals above 30 MHz to eliminate direct receiving of signals at 64.455 MHz and image interference at 130–160 MHz. The signals are then applied to the 1st mixer (Q26, Q27).

The 1st LO signal (64.9535–94.4565 MHz) enters the MAIN unit from the PLL unit via P1 (PLL unit: J4). The LO signal is amplified at Q5 and then applied to the 1st mixer.

The 1st mixer (Q26, Q27) uses two 2SK2171s to produce high level mixing with a high intercept point.

EXACT 1ST IF FREQUENCY

MODE	FREQUENCY (MHz)
USB	64.4565
LSB	64.4535
CW	64.4541
AM, CW-N	64.4550

4-1-5 1ST IF CIRCUIT (MAIN UNIT)

The 1st IF circuit filters and amplifies the 1st IF signals. The 1st IF signals from the 1st mixer circuit are applied to MCF (Monolithic Crystal Filter; FI1) to suppress out-of-band signals. The passband width of FI1 is ± 7.5 kHz/−6 dB. The filtered signals are applied to the 1st IF amplifier (Q28). AGC voltage is supplied to the 2nd gate of Q28.

4-1-6 2ND MIXER CIRCUIT (MAIN UNIT)

The 2nd mixer circuit mixes the amplified 1st IF signals and 2nd LO signal (64.00 MHz) to convert the 1st IF to a 2nd IF.

The amplified 1st IF signals from Q28 are converted to 455 kHz 2nd IF signals at the 2nd mixer (D124). D124 is a DBM (Double Balanced Mixer). The 2nd LO level is approx. 0 dBm.

The 2nd IF signals are applied to FI2 to suppress undesired signals such as the 2nd LO signal, and are then applied to the noise blanker gate (D10, D11).

EXACT 2ND IF FREQUENCY

MODE	FREQUENCY (kHz)
USB	456.5
LSB	453.5
CW	454.1
AM, CW-N	455.0

4-1-7 NOISE BLANKER CIRCUIT (MAIN UNIT)

The noise blanker circuit detects pulse type noise, and turns OFF the signal line when noise appears.

The 2nd IF signals from FI2 are applied to the noise blanker gate (D10, D11). A portion of the signals from FI2 are amplified at the noise amplifiers (Q10, Q12, Q13), then detected at the noise detector (D15). The detected signal from the noise detector is applied to the noise blanker switch (Q39).

A portion of the detected signals from the noise detector is applied to the noise AGC circuit (Q11, Q37, C211, R59, R214) to control the bias voltage of the noise amplifier (Q10, Q12).

The threshold level of the noise blanker switch (Q39) is set at 0.9 V. When the detected voltage exceeds the threshold level, Q40 outputs a blanking signal to close the noise blanker gate (D10, D11), depending on the pulse noise period.

When the operating frequency is changed, the "DNB" signal line becomes "LOW," turning Q40 ON through D72. In this case, the noise blanker gate prevents PLL click noise.

4-1-8 2ND IF CIRCUIT (MAIN UNIT)

The 2nd IF circuit amplifies and filters the 2nd IF signals.

The signals passed through the noise gate (D10, D11) are amplified at Q9. AGC voltage is supplied to the 2nd gate of Q9.

When SSB or CW mode is selected, the amplified signals pass through FI3 (FL-65). When an optional CW narrow filter is installed and CW-N mode is selected, the signals pass through the CW narrow filter. When AM mode is selected, the signals bypass the 2nd IF filter.

The filters are selected with mode selecting signals (SSB-CW, AM, CW-N) and the "T8V" voltage line.

The filtered signal is amplified at Q44–Q46 to obtain a detectable level. AGC voltage is supplied to the 2nd gate of Q46. A thermistor (R228), connected to the gate of Q45, improves the temperature characteristics of the receiver gain. R230 adjusts the receiver gain.

Output signals from Q45 are applied to the SSB/CW detector. Output signals from Q44 are shared between the AM detector and AGC detector.

4-1-9 BFO CIRCUIT (PLL UNIT)

BFO (Beat Frequency Oscillator) frequency is used at the SSB/CW detector and the balanced modulator. The IC-77 uses a PLL circuit for the BFO circuit.

The oscillated signal at the VCO (Q15, 45.33–45.65 MHz) is buffer-amplified at Q16 and applied to the divider (IC4). The signal is divided by 2 at IC4 and is applied to a PLL IC (IC3).

The signal is divided at the programmable divider section in IC3 and is then phase detected at the phase comparator section with a 5 kHz reference frequency. The phase detected signal is output from pin 7 and is then converted to a DC voltage (lock voltage) by the active loop filter (Q13, Q14). The lock voltage is applied to the varactor diode (D3) in the VCO circuit to change the capacitance of the diode and control the oscillation frequency.

The oscillating signal is then buffer-amplified at Q16, divided by 100 at IC4, filtered by the low-pass filter (L14, L15, C51–C55), and finally applied to the product detector (MAIN unit IC10) for receive demodulation.

BFO FREQUENCY IN EACH MODE

MODE	FREQUENCY (kHz)	
	RECEIVE	TRANSMIT
USB	456.5	
LSB	453.5	
CW	453.3	454.1
CW-N	454.2	455.0
AM	NO OUTPUT	455.0

4-1-10 SSB/CW DEMODULATOR CIRCUITS (MAIN UNIT)

In SSB or CW mode, the 2nd IF signal from the IF amplifier (Q45) is mixed with the BFO signal from the PLL unit at the product detector (IC10) to demodulate the 2nd IF signal into an AF signal. The detected signal (AF) from IC10 (pin 3) is applied to the AF input mode selector switch (IC5).

4-1-11 AM DEMODULATOR CIRCUITS (MAIN UNIT)

In AM mode, the 2nd IF signal from the buffer amplifier (Q44) passes through C198 and is detected at D71. The detected signal (AF) is then applied to the AF input mode selector switch (IC5).

4-1-12 AF INPUT MODE SELECTOR SWITCH (MAIN UNIT)

The AF signal from one of the detector circuits is applied to the AF input mode selector switch (IC5). IC5 consists of 4 analog switches which are selected with a mode signal and the squelch control signal. The AF signal is output from IC5 (pins 1, 4) and then applied to the AF amplifier circuit.

4-1-13 AGC CIRCUIT (MAIN UNIT)

The AGC (Automatic Gain Control) circuit reduces IF amplifier gain to keep the audio output at a constant level.

The receiver gain is determined by the voltage on the AGC line (Q33, collector). The voltage is usually set by D64 and the resistance ratio of R171, R172, R174 and R176.

The 2nd IF signal from the buffer amplifier (Q44) is detected at the AGC detector (D65) and is then applied to the DC amplifier (Q33). - 5 V is applied to the Q33 emitter to activate the AGC line with minus voltage.

When receiving strong signals, the detected voltage increases and the voltage of the AGC line decreases via the DC amplifier (Q33). As the AGC line is used for the bias voltage of the IF amplifiers (Q9, Q28, Q46), IF amplifier gain is decreased.

When the strong signal disappears, the AGC line voltage is released by C175 and R170 in CW mode to obtain a fast AGC release time. In SSB or AM mode, C174 and R169 are connected in parallel to obtain a slow AGC release time.

4-1-14 S-METER CIRCUIT (MAIN UNIT)

The S-meter circuit indicates the relative received signal strength while receiving by utilizing the AGC voltage which changes depending on the received signal strength.

The AGC bias voltage (time constant line) is applied to a differential amplifier (IC9 pin 6) where the difference between the bias and reference voltages is detected.

The resulting S-meter signal is applied to the A/D converter section in the CPU (FRONT unit IC1 pin 98) and the S/R/F indicator displays the relative signal strength. The reference voltage is adjusted with R175.

4-1-15 SQUELCH CIRCUIT (MAIN UNIT)

The squelch circuit mutes audio output when the S-meter signal is lower than the [SQL] control setting level.

The S-meter signal from IC9b (pin 7) is applied to the comparator (IC9a pin 2) through D63 to be compared with the threshold level set by the [SQL] control.

When the S-meter signal is lower than the threshold level, the comparator becomes "HIGH" and Q32 turns ON to deactivate the AF input mode selector switch (IC5 pins 5, 13). This cuts the AF signal OFF. This signal is then applied to Q31, turning OFF the [RX] indicator, and is also applied to the [MIC] connector (pin 4) and [ACC(1)] connector (pin 6).

AF CIRCUIT

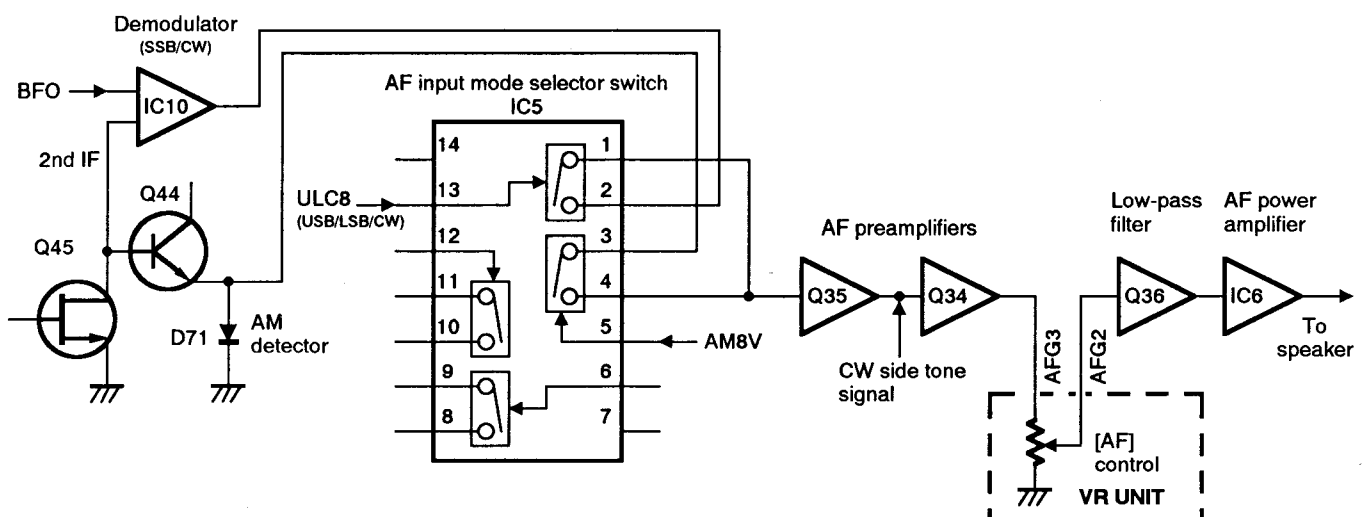

4-1-16 AF AMPLIFIER CIRCUIT (MAIN UNIT)

The AF amplifier amplifies the AF input signal to a suitable driving level for the speaker.

The AF signal from the AF input mode selector switch is applied to the AF preamplifiers (Q34, Q35). The CW side tone signal is applied to Q34.

The amplified signal is applied to the [AF] control (R1 on the AF unit) and then to the 2.3 kHz cut-off active low-pass filter (Q36). The AF signal output from Q36 is power-amplified at IC6 to drive the speaker.

4-2 TRANSMITTER CIRCUITS

4-2-1 MICROPHONE AMPLIFIER CIRCUIT (FRONT AND MAIN UNITS)

The microphone amplifier circuit amplifies the microphone input signals and outputs the amplified signal to the balanced modulator.

Audio signals from the [MIC] connector are adjusted at the [MIC] control (FRONT unit R61) and amplified at IC18c and IC18b (MAIN unit). External modulation input from the [ACC(1)] socket (pin 4) is also applied to IC18c via R341 (MAIN unit). The microphone bias voltage is supplied from the 8 V line via R62 and R63 (FRONT unit).

In AM mode, the maximum level of the IC18c output is limited by the ALC circuit (IC18d, Q57, D91). The maximum modulation level is set by R300 (MAIN unit).

4-2-2 BALANCED MODULATOR (MAIN UNIT)

The balanced modulator converts the AF signal from the microphone amplifier to a 455 kHz IF signal with a BFO signal.

Output signals from the microphone amplifier and the CW keying signal are applied to the balanced modulator (IC11 pin 5). The BFO signal from the PLL unit is applied to IC11 (pin 7) as a carrier signal.

IC11 is a double balanced mixer IC and outputs a double side band (DSB) signal with -40 dB carrier suppression.

R251 and R253 adjust the balanced level of IC11 for maximum carrier suppression. In CW mode, the CW keying signal upsets the balance to create a carrier signal. In AM mode, Q75 and R407 upset the balance to create an AM carrier signal.

4-2-3 CW KEYING CIRCUIT (MAIN UNIT)

The CW keyer is connected to Q68. When the CW key is closed, 8 V is output from Q68 and this voltage controls break-in operation, the side tone signal and the transmit signal.

The 8 V from Q68 is applied via D106, D101 and D102 to the balanced modulator (IC11) to unbalance the IC11 input bias voltage and create a carrier signal. R331 determines the transmit delay timing.

(1) BREAK-IN

The IC-77 is automatically set to transmit by CW keying. The 8 V from Q68 is applied to the base of Q66 via Q67. When the key is closed, Q66 grounds the SEND line for transmitting.

The transmit release delay time is determined by C290, R335 and R336.

(2) SIDE TONE

When the CW key is closed, the side tone circuit (Q64) oscillates and sends the signal to the AF circuit.

Normally, D100 is ON, and C285 is connected to the Q64 collector so that no oscillation occurs. When the CW key is closed, the 8 V from Q68 via D101 give D100 reverse bias to disconnect C285 from Q64. Q64 then oscillates with 800 Hz as a side tone signal. R328 prevents side tone click noise.

(3) KEYING

Keying is controlled at 2 points in the IC-77. The balanced mixer (IC11) stops the carrier output by recovering the balance of the input bias voltage. Q7, located at the 2nd IF mixer (D124) input, cuts the signal line.

C287, R330 and R331 determine the voltage wave form to IC11 (pin 6) to produce the keying wave form.

4-2-4 IF AMPLIFIER (MAIN UNIT)

The SSB/CW 455 kHz IF signal passes through FI3 (FL-65) to suppress unwanted sideband signals, then the signal is applied to a transmit IF amplifier (Q8). The optional CW narrow filter is not used in transmitting.

The amplified signal from Q8 is mixed with the 2nd LO signal and converted to a 64.455 MHz IF signal at D124. D124 is used in receiving and transmitting. The AM signal bypasses FI3, is amplified at Q8 and is then applied to D124.

The 64.455 MHz IF signal is filtered at FI1, amplified at the IF amplifier (Q4) and is then converted to the displayed frequency at the balanced mixer (Q2, Q3) with the 1st LO signal.

The gates of the IF amplifiers (Q4, Q8) are controlled by ALC bias voltage from the ALC circuit. A thermistor (R41), connected to the gate of Q8, improves the temperature characteristics of the transmitter gain. R36 adjusts the total transmitter gain.

4-2-5 RF CIRCUIT (MAIN AND PA UNITS)

The displayed frequency signal converted at the balanced mixer (MAIN unit Q2, Q3) is applied to the bandpass filter (L3–L5, C3–C7, C9, C10) where unwanted LO signal emission is reduced. The filtered signal is amplified at Q1, and is then applied to the PA unit via the attenuator.

The signals from the MAIN unit are amplified at the predrive amplifier (Q1), drive amplifier (Q2, Q3) and power amplifier (Q4, Q5) in the PA unit to obtain a stable 100 W of RF output power.

The predrive amplifier is a class A amplifier with a Vcc of 13.8 V. The drive amplifier is a class AB push-pull amplifier with a Vcc of 13.8 V. D1 controls bias voltage to the drive amplifier.

The impedance of the signal from the drive amplifier is converted at L2, then the signal is applied to the power amplifier (Q4, Q5). The power amplifier is a class AB push-pull amplifier and amplifies the input signal to 100 W. D2 and D3 control bias voltage to the power amplifier. The signal from the power amplifier is applied to one of the low-pass filters in the FILTER unit.

4-2-6 LOW-PASS FILTER CIRCUIT (FILTER UNIT)

The low-pass filter circuit consists of 6 Chebyshev low-pass filters to suppress the higher harmonic components. The signal from the power amplifier (Q4, Q5) is applied to one of the low-pass filters (depending on its frequency). The filter switching voltage from the MAIN unit (J4) is applied to the FILTER unit via P1.

The filtered signal passes through the SWR detector circuit (L13) and is then applied to the antenna connector.

4-2-7 ALC CIRCUIT (MAIN UNIT)

The ALC (Automatic Level Control) circuit controls the gain of IF amplifiers in order for the IC-77 to output a constant RF power set by the [RF PWR] control even when the supplied voltage shifts, etc.

The RF power signal level is detected at D8 (FILTER unit) and applied to the MAIN unit as the "FOR" voltage.

The "FOR" voltage from the FILTER unit is applied to IC15b (pin 6) in the MAIN unit. The "POC" voltage, set by the [RF PWR] control (FRONT unit R60), is applied to IC15b (pin 5) as the reference voltage.

When the "FOR" voltage exceeds the "POC" voltage, ALC bias voltage from IC15b (pin 7) controls the IF amplifiers (Q4, Q8). This adjusts the output power to the determined level by the [RF PWR] control until the "FOR" and "POC" voltages are equalized.

In AM mode, Q48 turns ON and C256 is connected to the "FOR" voltage line to obtain an averaging ALC operation. Q47 turns ON and the "POC" voltage is shifted for 40 W AM output power (maximum) through R274.

An external ALC input from the [ACC(1)] or [ACC(2)] socket or the [ALC] jack is applied to the buffer amplifier (Q50). External ALC operation is identical to that of the internal ALC.

4-2-8 APC CIRCUIT (MAIN UNIT)

The APC (Automatic Power Control) circuit protects the power amplifiers on the PA unit from high SWR and excessive current.

A reflected wave signal appears and increases on the antenna connector when the antenna is mismatched. D9 of the SWR detector circuit (L13, D8, D9) in the FILTER unit detects the signal and applies it to IC14a in the MAIN unit as the "REF" signal.

When the "REF" signal level increases, IC14a decreases the IALC line voltage via R264 to activate the ALC.

For the IC APC, the power transistor current is obtained by detecting the voltages ("ICH" and "ICL") which appear at both terminals of a 0.012 Ω resistor (PA unit R25). The detected voltage is applied to the differential amplifier (IC15a pins 2, 3). When the current of the final transistors is more than 22 A, IC15a controls the IALC line via D86 to prevent excessive current flow.

ALC CIRCUIT

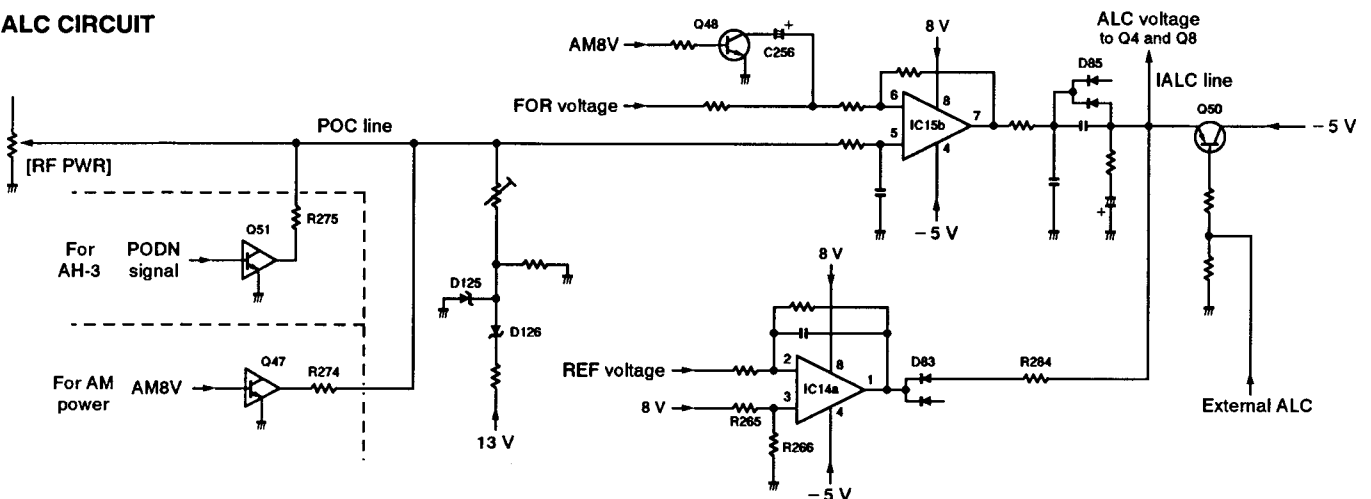

During tuning of an antenna with an optional AT-130, the "PODN" signal turns Q51 ON. As a result, the "POC" voltage is shifted for approx. 10 W output power.

4-2-9 TEMPERATURE PROTECTION CIRCUIT (MAIN UNIT)

A cooling fan (CHASSIS unit MF1) is activated while transmitting or if the temperature of Q4 exceeds the preset value.

While transmitting, PAT8 voltage is provided to MF1 via R29. Thermistor R29 on the PA unit detects the temperature of Q4. If the Q4 temperature is more than 50°C (122 °F), R29 becomes very low impedance and keeps Q73 and Q74 (MAIN unit) ON to rotate the cooling fan at high speed – even when the transceiver condition has changed from transmit to receive.

4-2-10 RF METER CIRCUIT (MAIN UNIT)

The "FOR" voltage from the FILTER unit is applied to the RF meter amplifier (IC14b pin 5). The amplified voltage is output from IC14b (pin 7) and then applied to the A/D converter section of the CPU (IC1 pin 99) in the FRONT unit. R268 adjusts the meter sensitivity and R273 and C254 are used for RF meter peak power hold.

4-3 PLL CIRCUITS

4-3-1 GENERAL DESCRIPTION

The PLL unit contains 2 PLL circuits for generating a 1st LO signal (64.9535–94.4565 MHz variable) and a BFO frequency (453.3–456.5 kHz). The 1st LO PLL employs a 1 loop DDS PLL whose reference oscillator is also used as the 2nd LO signal (64.00 MHz fixed). The DDS (Direct Digital Synthesizer) circuit performs signal sampling, generation of digital sine wave and digital phase detection.

4-3-2 1ST LO CIRCUIT (PLL UNIT)

The PLL contains 4 VCO circuits for all HF band coverage within 10 Hz steps (100 Hz step by programming and 10 Hz by an RIT). One of four VCO oscillation signals is buffer-amplified at Q26 and is then amplified at Q29, Q32 and Q30. The resulting signal is applied to the DDS IC (IC6).

The DDS IC outputs pulse-type signals. The signals are applied to the active loop filter (IC5) to be converted to a DC voltage (lock voltage).

The lock voltage is applied to the varactor diodes (D4–D7) in the VCO circuits to change the capacitance of these diodes and control the oscillation frequency. The VCO circuits are switched by the VCO switching signal ("VCO1"–"VCO4") from the DDS IC.

The VCO oscillating signal is then buffer-amplified at the buffer amplifier (Q26), amplified at Q27 and Q28, and finally applied to the MAIN unit as a 1st LO signal.

FREQUENCY CONSTRUCTION

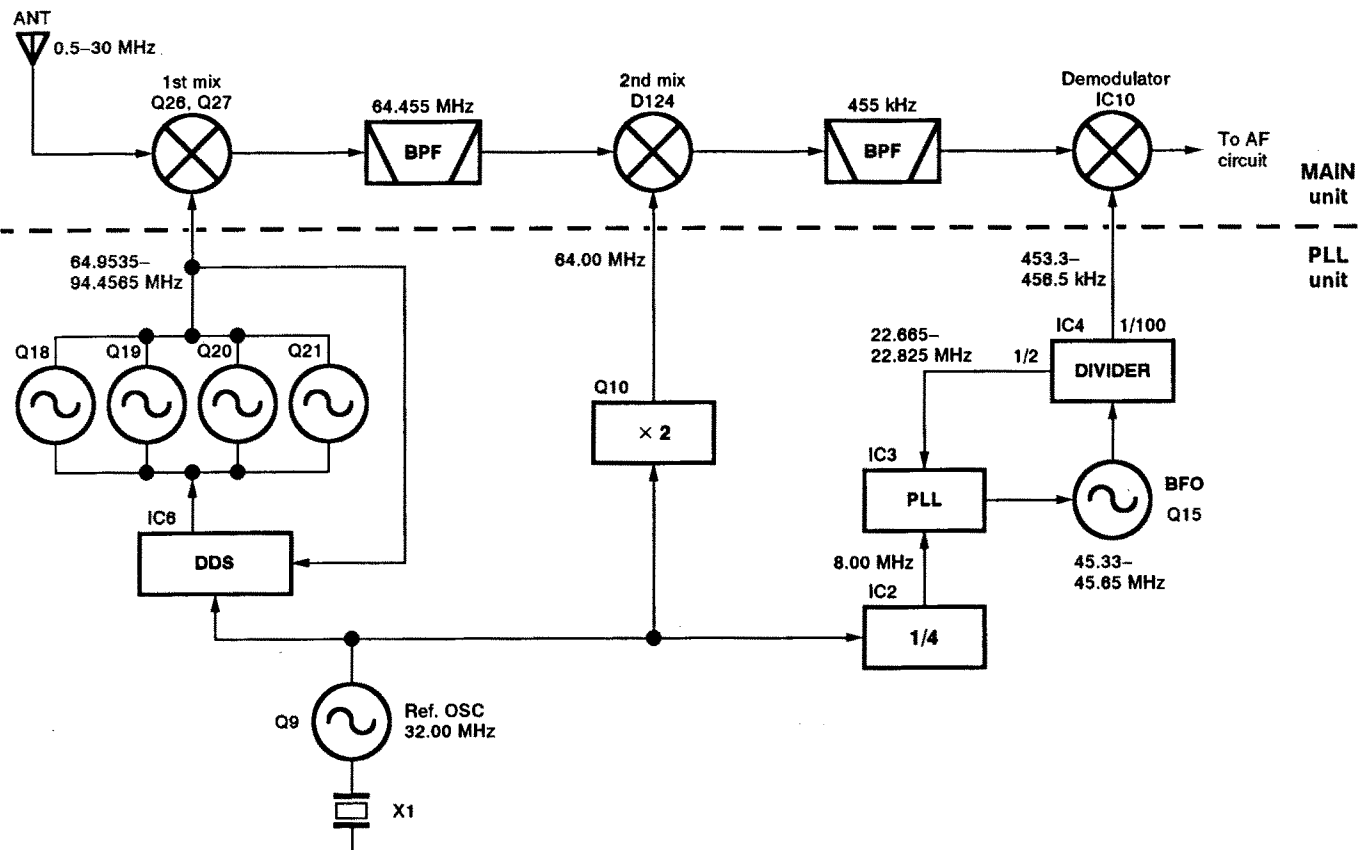

4-3-3 REFERENCE OSCILLATOR CIRCUIT (PLL UNIT)

The reference oscillator circuit consists of Q9 and X1. A 32.00 MHz reference frequency is oscillated to produce a 2nd LO signal, DDS reference frequency and BFO PLL reference frequency.

The reference frequency is applied to the DDS IC (IC6 pins 40, 41). The reference frequency is amplified at Q11 and is then divided by 4 at IC2. The 8.00 MHz frequency is divided by 1600 at the BFO PLL IC (IC3) to obtain the 5 kHz PLL reference frequency.

The 32.00 MHz reference frequency is multiplied by 2 at Q10 to obtain the 2nd LO signal. The resulting 64.00 MHz signal is filtered at the bandpass filter and is then applied to the MAIN unit via P1 as the 2nd LO signal.

4-4 LOGIC CIRCUITS

4-4-1 BAND SELECTION DATA (MAIN AND PLL UNITS)

To select the correct bandpass filter and low-pass filter, the CPU outputs the following band selection data from the I/O expander (MAIN unit IC3) depending on the displayed frequency.

The VCO selection data is output from the DDS IC in the PLL unit. The band voltage is produced at R366–R376 and R378 (MAIN unit).

BAND SELECTION DATA

FREQUENCY (MHz)	BPF	BAND VOLTAGE	LPF	VCO
0.5–1.59999	B0	7.4 V	L1	VCO1
1.6–1.99999	B1			
2.0–3.99999	B2	6.1 V	L2	
4.0–7.99999	B3	5.1 V	L3	
8.0–10.99999	B4	0.0 V	L4	VCO2
11.0–14.99999	B5	4.1 V		
15.0–21.99999	B6	3.2 V	L5	VCO3
22.0–30.00000	B7	2.2 V	L6	VCO4

4-4-2 RIT CONTROL (FRONT UNIT)

The [RIT] control shifts the "RITV" voltage in order to shift the receive frequency. The voltage is applied to the A/D converter section of the CPU (IC1 pin 1). The CPU shifts the N-data for the DDS IC.

4-4-3 CPU (LOGIC UNIT)

The CPU (IC1) contains an 8-bit CMOS CPU, a 32k-byte ROM, a 1k-byte RAM and an LCD driver. A 9.8304 MHz clock is used for rapid operation. The CPU controls the operating frequency, mode, function display, etc. The memory channel information is stored in the CPU using a lithium backup battery which has a normal life of more than 5 years.

The cloning function allows the IC-77 to transfer programmed memory contents to another IC-77. The Icom CI-V network system allows the IC-77 to be remotely controlled by a personal computer using an RS-232C I/O port.

• INPUT PORT ALLOCATIONS

PORT NAME	PIN NUMBER	DESCRIPTION
RITV	1	Input port for the detection of the [RIT] control position.
AVss, AVcc	2, 89	Input reference voltages for internal A/D converters.
OSC1, OSC2	7, 8	I/O ports for the CPU clock oscillation.
RES	9	Input port for the reset signal.
CIVCK	84	Input port for busy signal of the CI-V bus line. This port becomes "HIGH" when the bus line is busy.
CIVI	86	Input port for the CI-V data.
BAKUP	88	Detects the power voltage. When the signal is "LOW," the CPU is backed up.
KR0–KR3	90–93	Input ports for return signals of the key matrix.
KEY	94	Input port for the external antenna tuner (AT-130). This port becomes "LOW" while an external antenna tuner is tuning.
TRC	95	Input port for transmit/receive switching signal. This port becomes "HIGH" while transmitting.
SQLS	96	Input port for the squelch signal. This port becomes "LOW" when squelch is open.
SMV	98	Input port for the detection of the received signal strength.
POV	99	Input port for the detection of the RF output power.
MICV	100	Input port for the detection of [UP]/[DN] switch access.

• OUTPUT PORTS

PORT NAME	PIN NUMBER	DESCRIPTION
STAR	14	Outputs a control signal for the external antenna tuner (AT-130). Detects the connection of the external antenna tuner.
CON0–CON2	15–17	Output control signals for the DDS IC.
SRES	18	Outputs a reset signal for the DDS IC.
CK	19	Outputs a clock signal for the DDS IC, PLL IC and output expanders.
PLLE	20	Outputs an enable signal for the PLL data.
DATA	21	Outputs serial data to the DDS IC, PLL IC or output expander.
DSTB	22	Outputs a strobe signal for the DDS IC.
PSTB	23	Outputs a strobe signal for the BFO PLL.
BSTB	24	Outputs a strobe signal for the output expander (IC3) which outputs band signals.
MSTB	25	Outputs a strobe signal for the output expander (IC8) which outputs mode selection signals.
KSTB	26	Outputs a strobe signal for the output expander (IC6) which outputs key matrix strobe signals.
COM1–COM4	35–32	Output LCD common signals.
SEG1–SEG38	36–73	Output LCD segment signals.
PODN	77	Outputs a control signal for setting the tuning output power of the AT-130.
BEEP	78	Outputs a 1 kHz or 500 Hz beep tone.
PREV	79	Outputs a control signal for the preamplifier circuit.
ATTV	80	Outputs a control signal for the RF attenuator circuit.
NBV	81	Outputs a control signal for the noise blanker circuit.
CSEN	82	Outputs a control signal for tuning transmission.
CIVO	87	Output port for the CI-V data.

4-4-4 KEY MATRIX (FRONT UNIT)

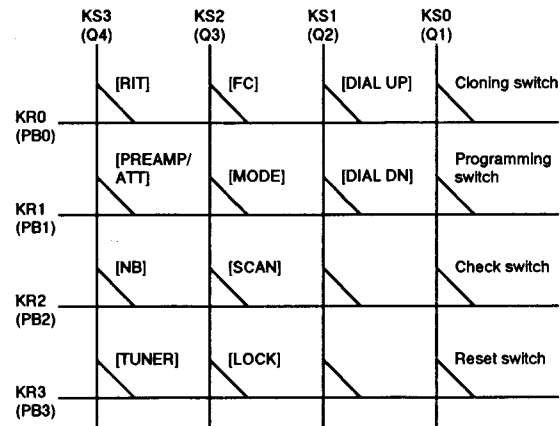

4-5 REGULATOR CIRCUITS

Either +8 V, +5 V or –5 V DC is supplied from a corresponding regulator circuit. +8 V, +5 V and –5 V DC are regulated at the following circuits using 13.8 V DC.

(1) +5 V REGULATOR (FRONT UNIT)

+5 V DC is provided by a three-terminal voltage regulator (IC4).

(2) +8 V REGULATOR (MAIN UNIT)

+8 V DC is provided by a three-terminal voltage regulator (IC17).

(3) –5 V REGULATOR (MAIN UNIT)

IC16 generates a negative pulse-type voltage by converting the DC input to AC voltages (approx. 6.7 kHz) as a multi-vibrator. The voltage is rectified at D80 and D81, regulated by a Zener diode (D82) and C249, and is then applied to the MAIN and PLL units.

SECTION 5 ADJUSTMENT PROCEDURES

5-1 PREPARATION BEFORE SERVICING

REQUIRED TEST EQUIPMENT

EQUIPMENT	GRADE AND RANGE	EQUIPMENT	GRADE AND RANGE
DC power supply	Output voltage : 13.8 V DC	AC millivoltmeter	Measuring range : 10 mV-10 V
	Current capacity : 30 A or more	DC voltmeter	Input impedance : 50 kΩ/DC or better
RF power meter (terminated type)	Measuring range : 10-200 W	Ammeter	Measurement capability: 1 A and 30 A
	Frequency range : 1.8-30 MHz	Audio generator	Frequency range : 300-3000 MHz
	Impedance : 50 Ω	Output level : 1-500 mV	
	SWR : Less than 1.2:1		
Frequency counter	Frequency range : 0.1-100 MHz	Attenuator	Power attenuation : 50 or 60 dB
	Frequency accuracy : ±1 ppm or better	Capacity : 150 W or more	
RF voltmeter	Frequency range : 0.1-100 MHz	Spectrum analyzer	Frequency range : At least 90 MHz
	Measuring range : 0.01-10 V	Spectrum bandwidth : ±100 kHz or more	
Digital multimeter	Input impedance : 10 MΩ/DC or better	FM deviation meter	Frequency range : At least 30 MHz
Standard signal generator (SSG)	Frequency range : 0.1-100 MHz	Measuring range : 0 to ±10 kHz	
	Output level : 0.1 μV-32 mV (-127 to -17 dBm)	Modulation analyzer	Frequency range : At least 30 MHz
Distortion meter	Frequency range : 1 kHz±10%	Measuring range : 0-100%	
	Measuring range : 1-100%	External speaker	Impedance : 8 Ω
Oscilloscope	Frequency range : DC-20 MHz	Max. input power : 5 W	
	Measuring range : 0.01-10 V		

CW: Clockwise CCW: Counterclockwise

CONNECTION

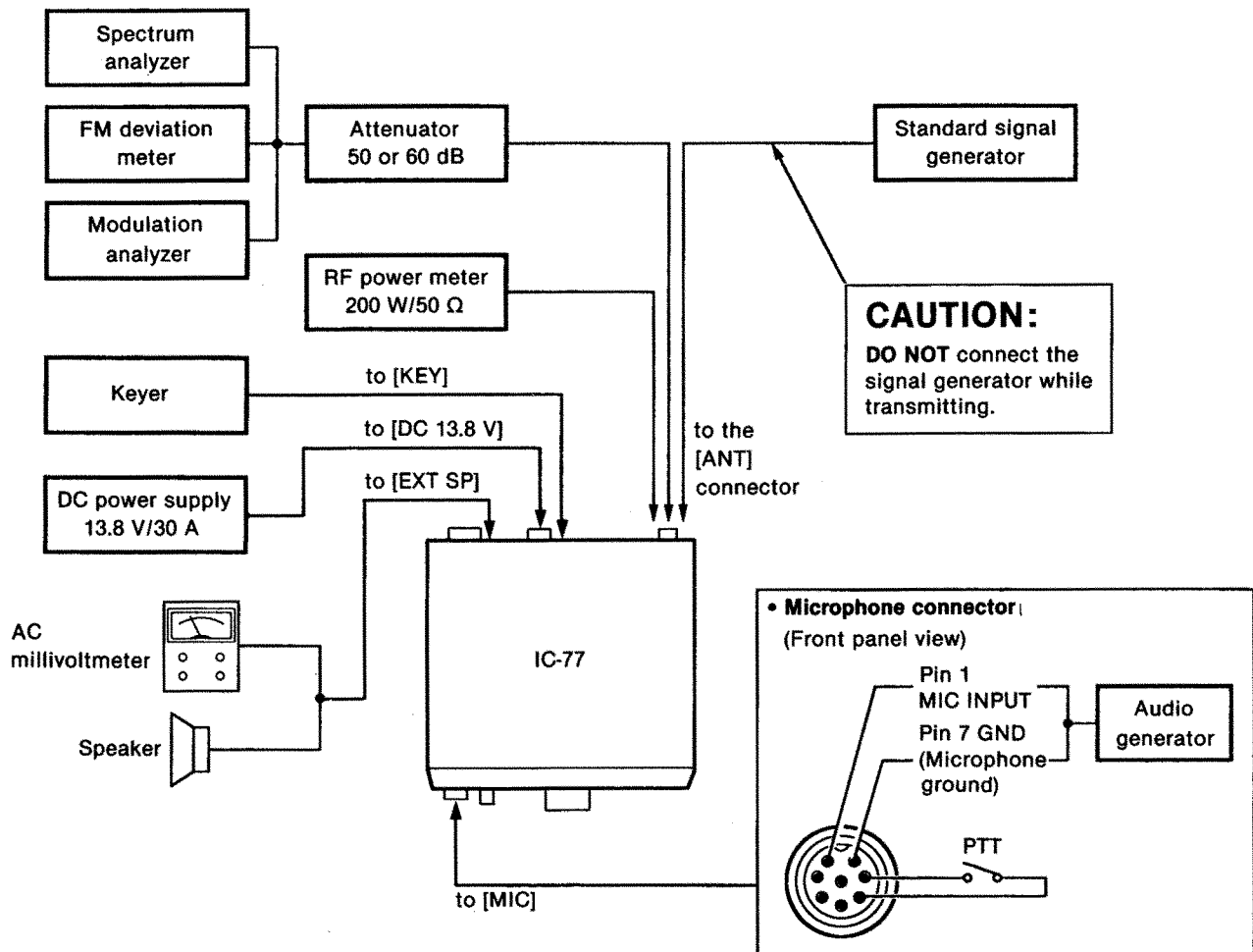

5-2 PLL ADJUSTMENT

ADJUSTMENT	ADJUSTMENT CONDITIONS	MEASUREMENT		VALUE	ADJUSTMENT POINT	
		UNIT	LOCATION		UNIT	ADJUST
REFERENCE FREQUENCY	1	PLL	Connect the frequency counter to P1.	Preset to center as shown below. 	PLL	C16
	2			64.0000 MHz		
	3		Connect the RF voltmeter to P1.	Maximum level		
	4	After adjustment, remove the resistor from P1 and re-plug P1.				
BFO PLL LOCK VOLTAGE	1	PLL	Connect the digital multimeter or oscilloscope to L10.	1.9 V DC	PLL	C39
LOCK VOLTAGE	1	PLL	Connect the digital multimeter or oscilloscope to R157.	6.0 V DC	PLL	C64
	2			6.0 V DC		C71
	3			6.0 V DC		C78
	4			6.0 V DC		C86
	5			More than 1.7 V DC		Verify

5-3 RECEIVER ADJUSTMENT

ADJUSTMENT	ADJUSTMENT CONDITIONS	MEASUREMENT		VALUE	ADJUSTMENT POINT	
		UNIT	LOCATION		UNIT	ADJUST
TOTAL GAIN	1	Rear panel	Connect the AC millivoltmeter to the [EXT SP] jack with an 8 Ω load.	Maximum audio output level	MAIN	Adjust in sequence L75, L77, L78, L82, L81, L80
	2					

* This output level of the standard signal generator (SSG) is indicated as SSG's open circuit.

• PLL UNIT

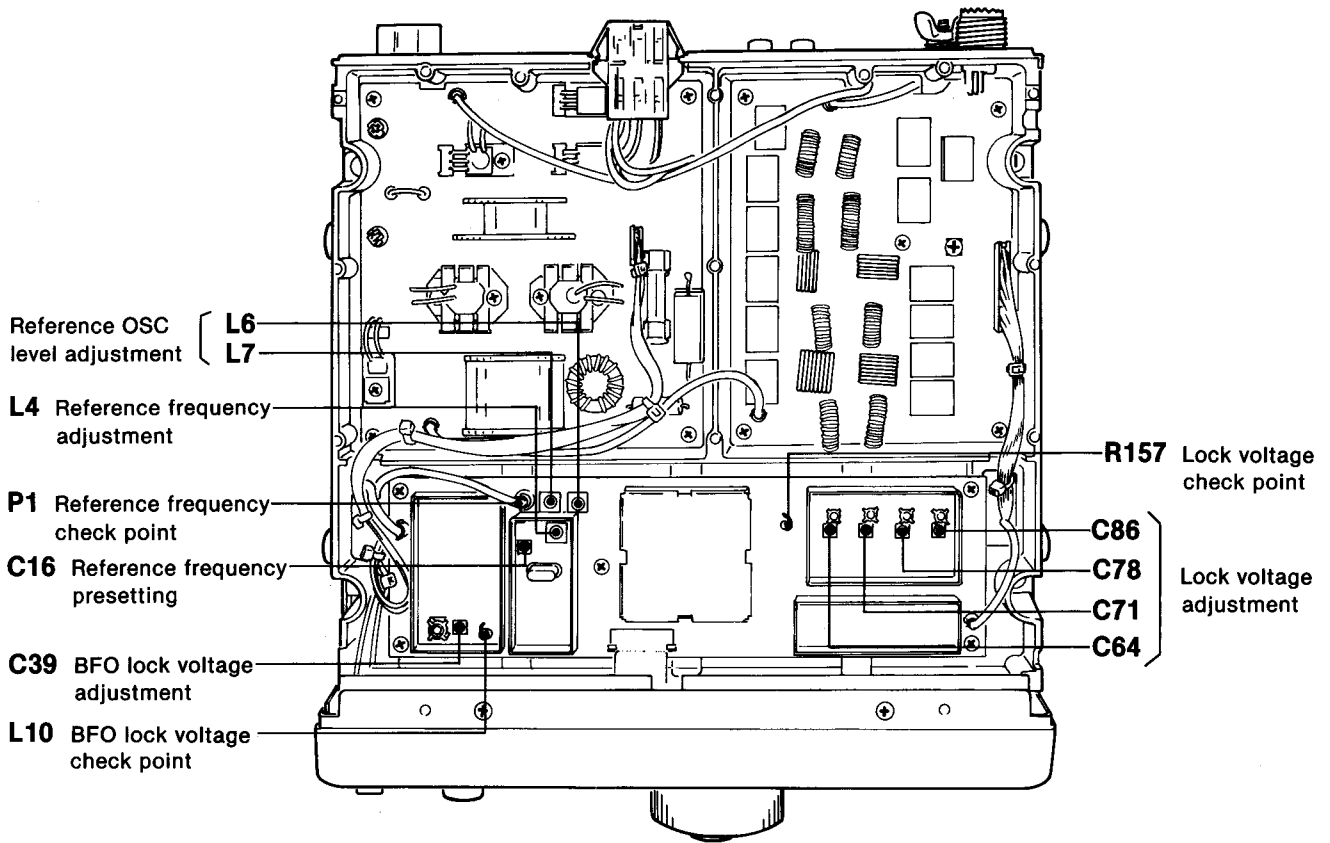

• MAIN UNIT

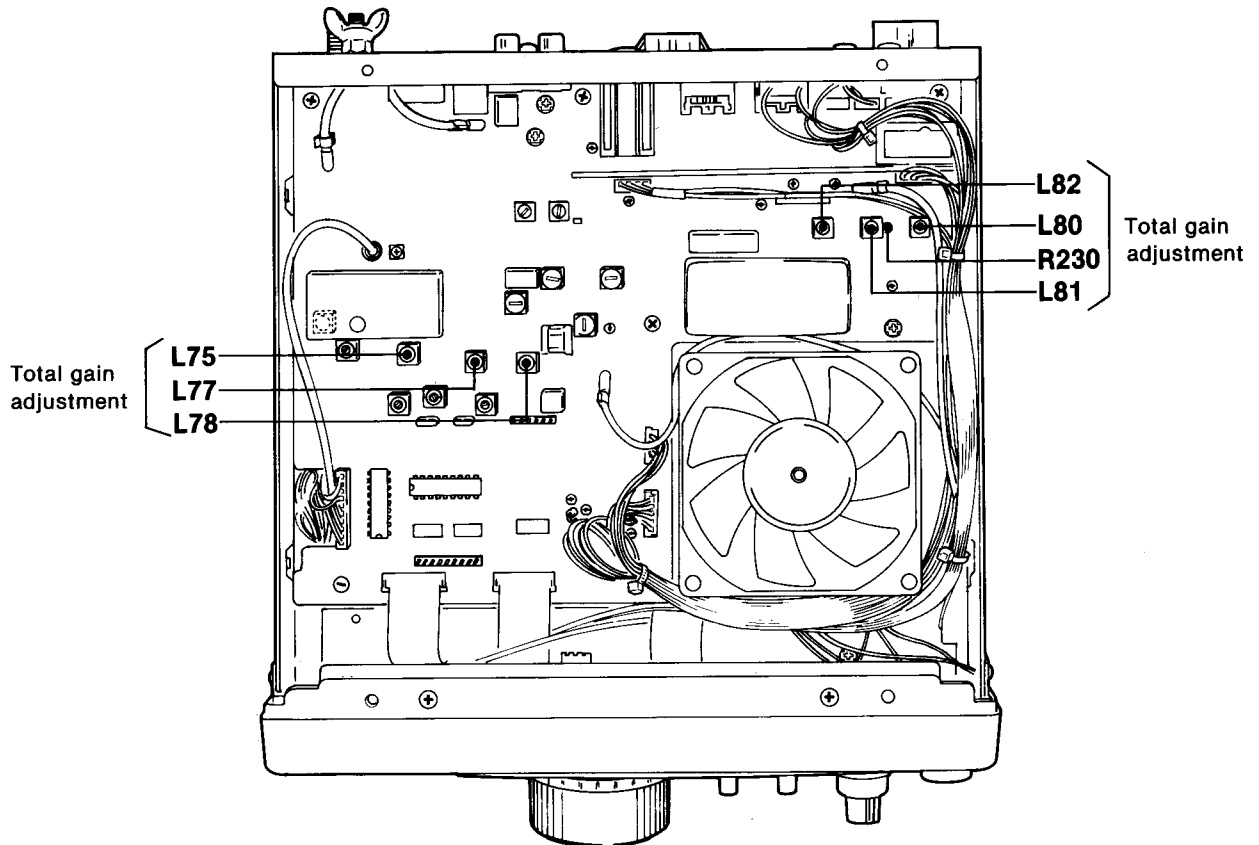

RECEIVER ADJUSTMENT (CONTINUED)

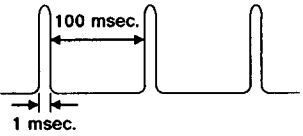
ADJUSTMENT		ADJUSTMENT CONDITIONS	MEASUREMENT		VALUE	ADJUSTMENT POINT	
			UNIT	LOCATION		UNIT	ADJUST
S-METER	1	<ul style="list-style-type: none"> • Displayed frequency: 14.1000 MHz • Mode : USB • [RIT] switch : OFF • [NB] switch : OFF • [PRE AMP] switch : OFF • Connect the SSG to the [ANT] connector and set as: Frequency : 14.1000 MHz Level : 25 μV^* (-79 dBm) Modulation: OFF • Receiving 	Function display	S-indicator	5 dots just appear. 	MAIN	R175
NOISE BLANKER	1	<ul style="list-style-type: none"> • Displayed frequency: 14.1000 MHz • Mode : USB • [NB] switch : OFF • [PRE AMP] switch : ON • Receiving • Connect the SSG to the [ANT] connector and set as: Frequency : 14.1000 MHz Level : 3.2 μV^* (-97 dBm) Modulation: OFF • Apply the following signal to the SSG's output. 	MAIN	Connect the oscilloscope to R68.	Adjust for maximum waveform on the oscilloscope.	MAIN	L23, L24
	2	<ul style="list-style-type: none"> • [NB] switch : ON • Set the SSG as: Level : 10 μV^* (-87 dBm) Modulation: OFF • Apply the same signal as shown above. 					
1st LO TRAP	1	<ul style="list-style-type: none"> • Displayed frequency: 14.1000 MHz • Mode : USB • [PRE AMP] switch : OFF • Connect the SSG to P1 (MAIN unit) and set as: Frequency : 64.4550 MHz Level : 3.2 μV^* (-97 dBm) Modulation: OFF • Receiving 	Rear panel	Connect the AC millivoltmeter to the [EXT SP] jack with an 8 Ω load.	Adjust for minimum speaker output.	MAIN	C387
	1	<ul style="list-style-type: none"> • Receiving 					
RIT	1	<ul style="list-style-type: none"> • Displayed frequency: 14.1000 MHz • Mode : USB • Connect the SSG to the [ANT] connector and set as: Level : 50 μV^* (-73 dBm) Modulation: OFF • [RIT] control : Center • [RIT] switch : ON and OFF • Receiving 	Front panel	Speaker	Same tone pitch on both conditions.	VR	R3

* This output level of the standard signal generator (SSG) is indicated as SSG's open circuit.

• MAIN AND VR UNITS

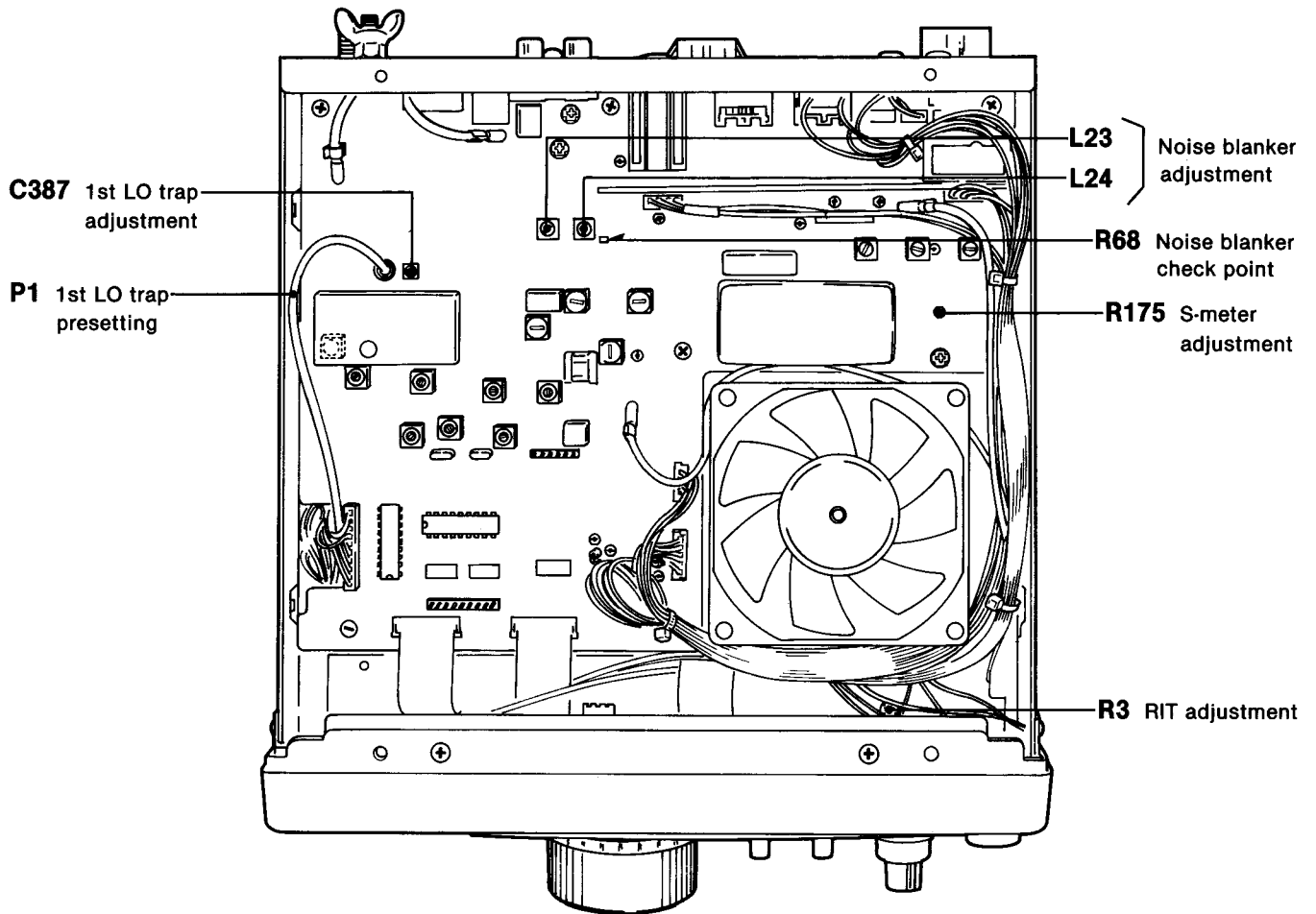

5-4 TRANSMITTER ADJUSTMENT

ADJUSTMENT	ADJUSTMENT CONDITIONS	MEASUREMENT		VALUE	ADJUSTMENT POINT	
		UNIT	LOCATION		UNIT	ADJUST
IDLING CURRENT Ⓐ For drive transistors	<ul style="list-style-type: none"> • Displayed frequency: 14.1000 MHz • Mode : USB • [RF PWR] control : Max. CCW • [MIC] control : Max. CCW • Transmitting 	PA	Unsolder W11 and connect the ammeter to the unsoldering points.	100 mA	PA	R21
			Unsolder R25 and connect the ammeter to the unsoldering points.			300 mA
	Ⓑ For final transistors	2	After adjustment, re-solder W11 and R25.			
SWR DETECTOR	<ul style="list-style-type: none"> • Displayed frequency: 14.1000 MHz • Mode : USB • [RF PWR] control : Max. CCW • Connect the jumper wire between R267 (MAIN unit) and a ground. • Connect the audio generator to the [MIC] connector and set as: Level : 30 mV Frequency : 1.5 kHz • Transmitting 	Rear panel	Connect the RF power meter to the [ANT] connector.	100 W	Front panel	[MIC] control
		MAIN	Connect the DC voltmeter to J4 (pin 7).	Minimum	FILTER	C17
	3	After adjustment, remove the jumper wire from R267.				
TRANSMIT GAIN	<ul style="list-style-type: none"> • Displayed frequency: 14.1000 MHz • Mode : USB • [RF PWR] control : Max. CW • R180 (MAIN unit) : Max. CW • R325, R336 (MAIN unit): Center • Connect the audio generator to the [MIC] connector and set as: Level : 3 mV Frequency : 1.5 kHz • Transmitting 	Rear panel	Connect the RF power meter to the [ANT] connector.	50 W	Front panel	[MIC] control
				Maximum	MAIN	L14, L76, L13, L8, L7
OUTPUT POWER	<ul style="list-style-type: none"> • Displayed frequency: 14.1000 MHz • Mode : USB • [RF PWR] control : Max. CW • [MIC] control : Center • Connect the audio generator to the [MIC] connector and set as: Level : 30 mV Frequency : 1.5 kHz • Transmitting 	Rear panel	Connect the RF power meter to the [ANT] connector.	100 W	MAIN	R276
Ic APC	<ul style="list-style-type: none"> • Displayed frequency: 14.1000 MHz • Mode : USB • [RF PWR] control : Max. CW • [MIC] control : Center • Connect the jumper wire between J4 (pin 8, MAIN unit) and a ground. • Connect the audio generator to the [MIC] connector and set as: Level : 30 mV Frequency : 1.5 kHz • Transmitting 	Rear panel	Connect the ammeter between the DC power supply and IC-77.	22 A	MAIN	R285

• PA AND FILTER UNITS

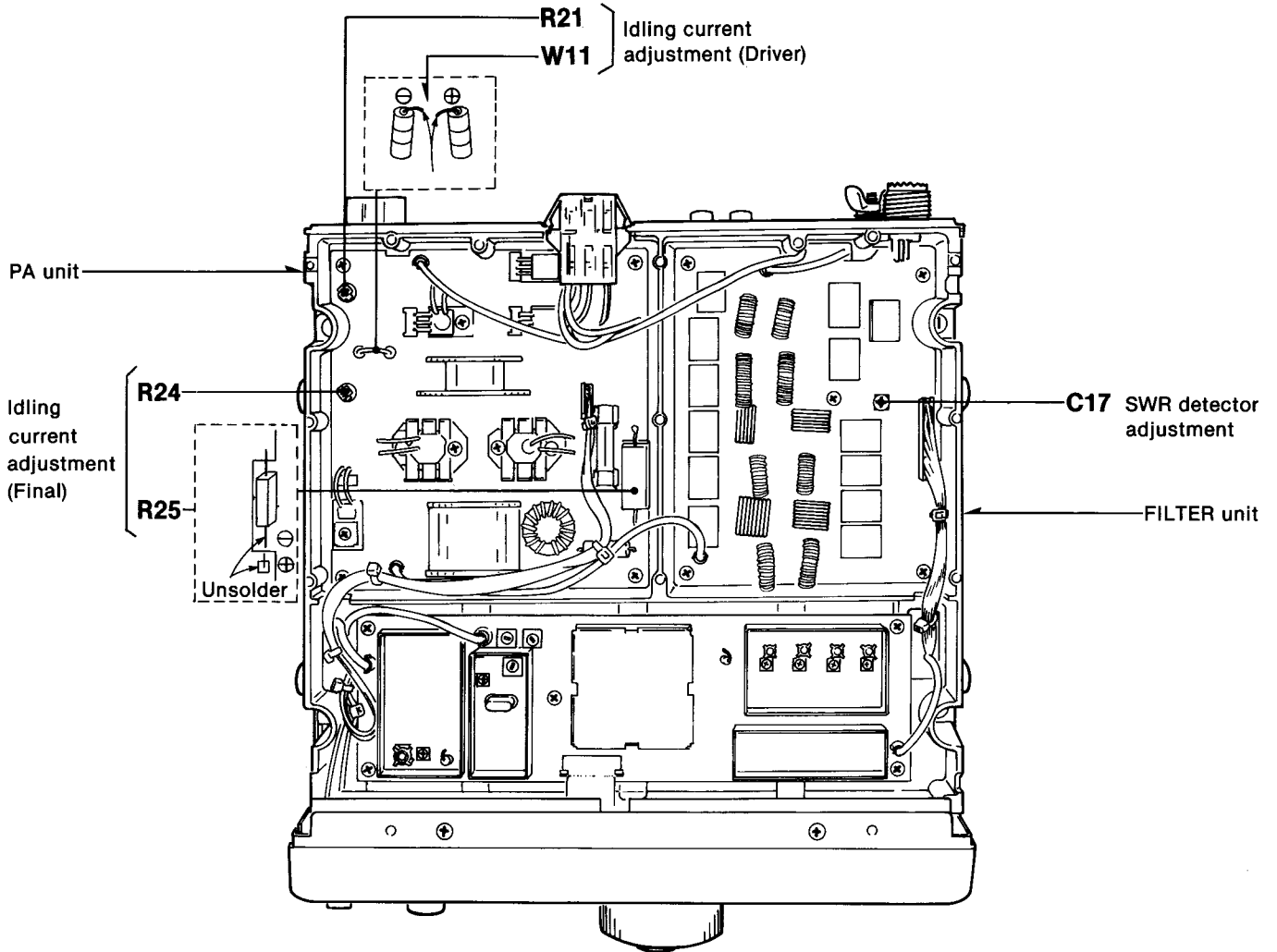

• MAIN UNIT

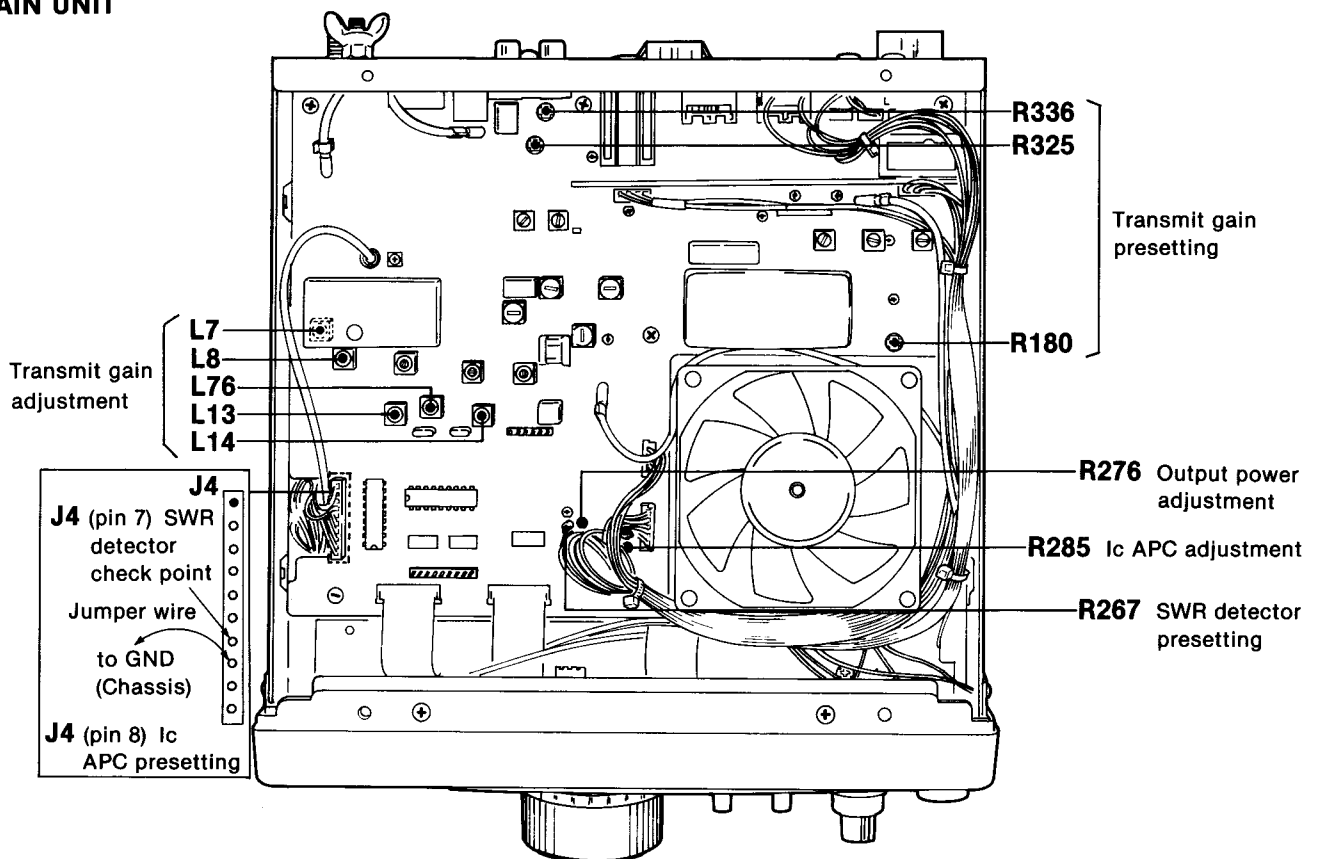

TRANSMITTER ADJUSTMENT (CONTINUED)

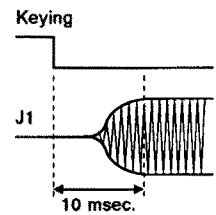
ADJUSTMENT	ADJUSTMENT CONDITIONS	MEASUREMENT		VALUE	ADJUSTMENT POINT		
		UNIT	LOCATION		UNIT	ADJUST	
Po METER	1	<ul style="list-style-type: none"> Displayed frequency: 14.1000 MHz Mode : USB Connect the audio generator to the [MIC] connector and set as: Level : 30 mV Frequency : 1 kHz Transmitting 	Rear panel	Connect the RF power meter to the [ANT] connector.	85 W	Front panel	[RF PWR] control
	2		Function display	RF indicator	8 dots just appear. 	MAIN	R268
CARRIER SUPPRESSION	1	<ul style="list-style-type: none"> Displayed frequency: 14.1000 MHz Mode : USB [MIC] control : Max. CCW Apply no signal to the [MIC] connector. Transmitting 	Rear panel	Connect the spectrum analyzer to the [ANT] connector via the attenuator.	Minimum carrier level (Less than -40 dB)	MAIN	R251, R253 (Alternate adjustment)
AM MODULATION (#02 only)	1	<ul style="list-style-type: none"> Displayed frequency: 14.1000 MHz Mode : AM R300 (MAIN unit) : Center [RF PWR] control : Max. CW [MIC] control : Center Connect the audio generator to the [MIC] connector and set as: Level : 3 mV Frequency : 1 kHz Transmitting 	Rear panel	Connect the modulation analyzer to the [ANT] connector via the attenuator.	70% modulation	MAIN	R407
	2				<ul style="list-style-type: none"> Set the audio generator as: Level : 30 mV Frequency : 1 kHz 		90% modulation
CW DELAY TIME (#02 only)	1	<ul style="list-style-type: none"> Displayed frequency: 14.1000 MHz Mode : CW [RF PWR] control : Max. CW Connect a keyer to the [KEY] jack and key down. 	MAIN	Connect the oscilloscope to J1 and the keyer.	Adjust as follows: Keying 	MAIN	R331

• MAIN UNIT

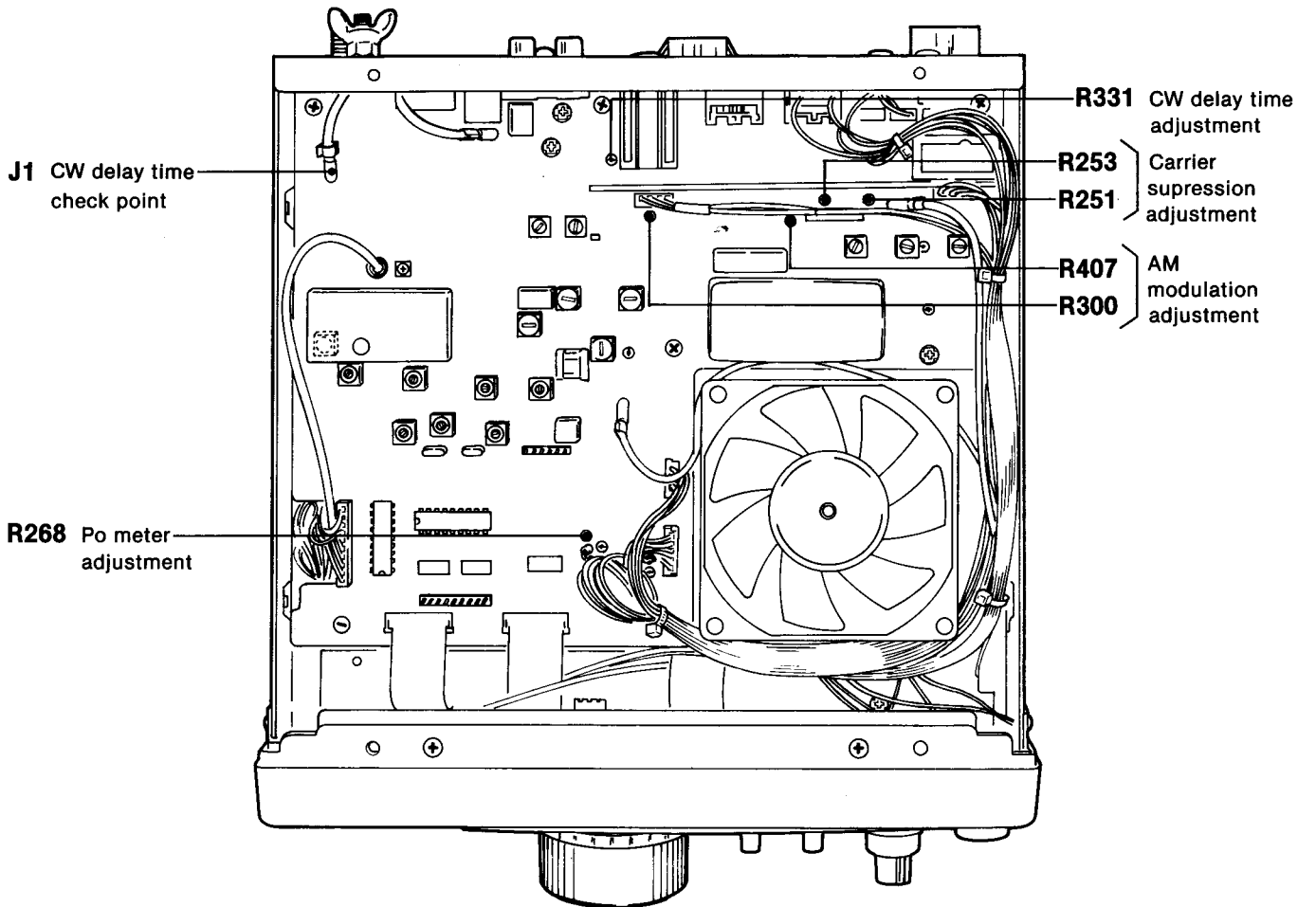

SECTION 6 PARTS LIST

[CHASSIS PARTS]

REF. NO.	ORDER NO.	DESCRIPTION	
W9	8900004360	CABLE	OPC-424
W10	8900004360	CABLE	OPC-424
W11	8900004360	CABLE	OPC-424

[FRONT UNIT]

REF. NO.	ORDER NO.	DESCRIPTION	
R7	7030003640	S. RESISTOR	ERJ3GEYJ 473 V (47 kΩ)
R8	7030003520	S. RESISTOR	ERJ3GEYJ 472 V (4.7 kΩ)
R9	7030003560	S. RESISTOR	ERJ3GEYJ 103 V (10 kΩ)
R10	7510000310	THERMISTOR	ERT-D2ZHL 802S
R11	7030003400	S. RESISTOR	ERJ3GEYJ 471 V (470 Ω)
R12	7030001060	S. RESISTOR	MCR50JZHJ 27 Ω (270)
R13	7030003680	S. RESISTOR	ERJ3GEYJ 104 V (100 kΩ)
R14	7030003720	S. RESISTOR	ERJ3GEYJ 224 V (220 kΩ)
R15	7030003720	S. RESISTOR	ERJ3GEYJ 224 V (220 kΩ)
R16	7030003760	S. RESISTOR	ERJ3GEYJ 474 V (470 kΩ)
R17	7030003440	S. RESISTOR	ERJ3GEYJ 102 V (1 kΩ)
R18	7030003680	S. RESISTOR	ERJ3GEYJ 104 V (100 kΩ)
R19	7030003320	S. RESISTOR	ERJ3GEYJ 101 V (100 Ω)
R20	7030003320	S. RESISTOR	ERJ3GEYJ 101 V (100 Ω)
R21	7030003320	S. RESISTOR	ERJ3GEYJ 101 V (100 Ω)
R22	7030003320	S. RESISTOR	ERJ3GEYJ 101 V (100 Ω)
R23	7030003320	S. RESISTOR	ERJ3GEYJ 101 V (100 Ω)
R24	7030003320	S. RESISTOR	ERJ3GEYJ 101 V (100 Ω)
R25	7030003440	S. RESISTOR	ERJ3GEYJ 102 V (1 kΩ)
R26	7030003440	S. RESISTOR	ERJ3GEYJ 102 V (1 kΩ)
R28	7030003440	S. RESISTOR	ERJ3GEYJ 102 V (1 kΩ)
R29	7030003440	S. RESISTOR	ERJ3GEYJ 102 V (1 kΩ)
R30	7030003640	S. RESISTOR	ERJ3GEYJ 473 V (47 kΩ)
R31	7030003640	S. RESISTOR	ERJ3GEYJ 473 V (47 kΩ)
R32	7030003440	S. RESISTOR	ERJ3GEYJ 102 V (1 kΩ)
R33	7030003440	S. RESISTOR	ERJ3GEYJ 102 V (1 kΩ)
R34	7030003440	S. RESISTOR	ERJ3GEYJ 102 V (1 kΩ)
R35	7030003640	S. RESISTOR	ERJ3GEYJ 473 V (47 kΩ)
R36	7030003440	S. RESISTOR	ERJ3GEYJ 102 V (1 kΩ)
R37	7030003280	S. RESISTOR	ERJ3GEYJ 470 V (47 Ω)
R38	7030003640	S. RESISTOR	ERJ3GEYJ 473 V (47 kΩ)
R40	7030003640	S. RESISTOR	ERJ3GEYJ 473 V (47 kΩ)
R41	7030003640	S. RESISTOR	ERJ3GEYJ 473 V (47 kΩ)
R42	7030003800	S. RESISTOR	ERJ3GEYJ 105 V (1 MΩ)
R43	7030003440	S. RESISTOR	ERJ3GEYJ 102 V (1 kΩ)
R44	7030003440	S. RESISTOR	ERJ3GEYJ 102 V (1 kΩ)
R45	7030003440	S. RESISTOR	ERJ3GEYJ 102 V (1 kΩ)
R46	7030003440	S. RESISTOR	ERJ3GEYJ 102 V (1 kΩ)
R47	7030003440	S. RESISTOR	ERJ3GEYJ 102 V (1 kΩ)
R48	7030003320	S. RESISTOR	ERJ3GEYJ 101 V (100 Ω)
R49	7030003320	S. RESISTOR	ERJ3GEYJ 101 V (100 Ω)
R50	7030003320	S. RESISTOR	ERJ3GEYJ 101 V (100 Ω)
R51	7030003320	S. RESISTOR	ERJ3GEYJ 101 V (100 Ω)
R52	7030003640	S. RESISTOR	ERJ3GEYJ 473 V (47 kΩ)
R53	7030003640	S. RESISTOR	ERJ3GEYJ 473 V (47 kΩ)
R54	7030003640	S. RESISTOR	ERJ3GEYJ 473 V (47 kΩ)
R55	7030003640	S. RESISTOR	ERJ3GEYJ 473 V (47 kΩ)
R56	7030003480	S. RESISTOR	ERJ3GEYJ 222 V (2.2 kΩ)
R57	7030003640	S. RESISTOR	ERJ3GEYJ 473 V (47 kΩ)
R58	7030003640	S. RESISTOR	ERJ3GEYJ 473 V (47 kΩ)
R59	7030003440	S. RESISTOR	ERJ3GEYJ 102 V (1 kΩ)
R60	7210002190	VARIABLE	EVU-FLAEA4 B14 (10KB) [RF PWR]
R61	7210002190	VARIABLE	EVU-FLAEA4 B14 (10KB) [MIC]
R62	7030003440	S. RESISTOR	ERJ3GEYJ 102 V (1 kΩ)
R63	7030003280	S. RESISTOR	ERJ3GEYJ 470 V (47 Ω)
R64	7030001140	S. RESISTOR	MCR50JZHJ 120 Ω (121)
R65	7030001140	S. RESISTOR	MCR50JZHJ 120 Ω (121)
R66	7030003480	S. RESISTOR	ERJ3GEYJ 222 V (2.2 kΩ)
R67	7030003400	S. RESISTOR	ERJ3GEYJ 471 V (470 Ω)
R68	7030003560	S. RESISTOR	ERJ3GEYJ 103 V (10 kΩ)
R69	7030003560	S. RESISTOR	ERJ3GEYJ 103 V (10 kΩ)
R71	7030003680	S. RESISTOR	ERJ3GEYJ 104 V (100 kΩ)
R72	7030003590	S. RESISTOR	ERJ3GEYJ 183 V (18 kΩ)
R73	7030003540	S. RESISTOR	ERJ3GEYJ 682 V (6.8 kΩ)
R74	7030003620	S. RESISTOR	ERJ3GEYJ 333 V (33 kΩ)
R75	7030003640	S. RESISTOR	ERJ3GEYJ 473 V (47 kΩ)
R77	7030003640	S. RESISTOR	ERJ3GEYJ 473 V (47 kΩ)
R78	7030003640	S. RESISTOR	ERJ3GEYJ 473 V (47 kΩ)

[FRONT UNIT]

REF. NO.	ORDER NO.	DESCRIPTION	
IC1	1140003960	S. IC	HD6433834A04H
IC2	1130005720	S. IC	TC7W04F (TE12L)
IC3	1110001550	S. IC	S-8054ALB-LM-T1
IC4	1180000420	S. IC	TA78L05F (TE12R)
IC5	1130007040	S. IC	TC7W32F (TE12L)
IC6	1130000830	S. IC	μPD4094BG-T1
Q1	1510000510	S. TRANSISTOR	2SA1576 T107 R
Q2	1530002060	S. TRANSISTOR	2SC4081 T107 R
Q3	1530002060	S. TRANSISTOR	2SC4081 T107 R
Q4	1520000200	S. TRANSISTOR	2SB798-T2 DK
Q5	1530002060	S. TRANSISTOR	2SC4081 T107 R
Q8	1530002060	S. TRANSISTOR	2SC4081 T107 R
Q9	1510000510	S. TRANSISTOR	2SA1576 T107 R
D1	1160000060	S. DIODE	DAN202U T107
D2	1160000060	S. DIODE	DAN202U T107
D3	1160000060	S. DIODE	DAN202U T107
D4	1160000050	S. DIODE	DAP202U T107
D5	1160000050	S. DIODE	DAP202U T107
D6	1160000050	S. DIODE	DAP202U T107
D7	1160000050	S. DIODE	DAP202U T107
D8	1160000050	S. DIODE	DAP202U T107
D9	1160000050	S. DIODE	DAP202U T107
D10	1160000050	S. DIODE	DAP202U T107
D11	1160000060	S. DIODE	DAN202U T107
D12	1160000060	S. DIODE	DAN202U T107 (#01)
D14	1160000060	S. DIODE	DAN202U T107
D15	1160000060	S. DIODE	DAN202U T107
D16	1160000060	S. DIODE	DAN202U T107
D17	1730000410	S. ZENER	RD5.1M-T2B2
D18	1160000060	S. DIODE	DAN202U T107
D21	1160000060	S. DIODE	DAN202U T107
D22	1160000060	S. DIODE	DAN202U T107
D23	1160000060	S. DIODE	DAN202U T107
X1	6050008160	S. XTAL	CR-410
L1	6180000990	COIL	LAL 04NA 101K
L2	6200003260	S. COIL	NL 322522T-101J
L3	6200003260	S. COIL	NL 322522T-101J
L4	6200003260	S. COIL	NL 322522T-101J
L5	6200003260	S. COIL	NL 322522T-101J
L6	6200003260	S. COIL	NL 322522T-101J
L7	6200003260	S. COIL	NL 322522T-101J
R1	7030003800	S. RESISTOR	ERJ3GEYJ 105 V (1 MΩ)
R2	7030003500	S. RESISTOR	ERJ3GEYJ 332 V (3.3 kΩ)
R3	7030003560	S. RESISTOR	ERJ3GEYJ 103 V (10 kΩ)
R4	7030003560	S. RESISTOR	ERJ3GEYJ 103 V (10 kΩ)
R5	7030003560	S. RESISTOR	ERJ3GEYJ 103 V (10 kΩ)
R6	7030003640	S. RESISTOR	ERJ3GEYJ 473 V (47 kΩ)

S. = Surface mount

[FRONT UNIT]

REF. NO.	ORDER NO.	DESCRIPTION	
R79	7030003640	S. RESISTOR	ERJ3GEYJ 473 V (47 kΩ)
R80	7030003640	S. RESISTOR	ERJ3GEYJ 473 V (47 kΩ)
R94	7030003520	S. RESISTOR	ERJ3GEYJ 472 V (4.7 kΩ)
C1	4030006620	S. CERAMIC	C1608 SL 1H 120J-T-A
C2	4030006620	S. CERAMIC	C1608 SL 1H 120J-T-A
C3	4030008630	S. CERAMIC	C1608 JF 1C 104Z-T-A
C4	4030008630	S. CERAMIC	C1608 JF 1C 104Z-T-A
C5	4030008630	S. CERAMIC	C1608 JF 1C 104Z-T-A
C6	4510004590	ELECTROLYTIC	16 MV 470 HC
C7	4510003910	ELECTROLYTIC	16 MV 47 HW
C8	4030008630	S. CERAMIC	C1608 JF 1C 104Z-T-A
C9	4030008630	S. CERAMIC	C1608 JF 1C 104Z-T-A
C10	4510003910	ELECTROLYTIC	16 MV 47 HW
C11	4030009000	S. CERAMIC	C2012 JB 1C 224K-T-A
C12	4030006750	S. CERAMIC	C1608 SL 1H 101J-T-A
C13	4030006750	S. CERAMIC	C1608 SL 1H 101J-T-A
C14	4030006750	S. CERAMIC	C1608 SL 1H 101J-T-A
C15	4030006750	S. CERAMIC	C1608 SL 1H 101J-T-A
C16	4030006750	S. CERAMIC	C1608 SL 1H 101J-T-A
C17	4030006750	S. CERAMIC	C1608 SL 1H 101J-T-A
C18	4030006880	S. CERAMIC	C1608 JB 1H 472K-T-A
C19	4030006880	S. CERAMIC	C1608 JB 1H 472K-T-A
C21	4030006880	S. CERAMIC	C1608 JB 1H 472K-T-A
C22	4030006880	S. CERAMIC	C1608 JB 1H 472K-T-A
C23	4030006880	S. CERAMIC	C1608 JB 1H 472K-T-A
C24	4030006880	S. CERAMIC	C1608 JB 1H 472K-T-A
C25	4030006880	S. CERAMIC	C1608 JB 1H 472K-T-A
C26	4030006880	S. CERAMIC	C1608 JB 1H 472K-T-A
C27	4030006880	S. CERAMIC	C1608 JB 1H 472K-T-A
C28	4030006880	S. CERAMIC	C1608 JB 1H 472K-T-A
C29	4030006880	S. CERAMIC	C1608 JB 1H 472K-T-A
C30	4030006880	S. CERAMIC	C1608 JB 1H 472K-T-A
C31	4030006750	S. CERAMIC	C1608 SL 1H 101J-T-A
C32	4030006880	S. CERAMIC	C1608 JB 1H 472K-T-A
C33	4030006880	S. CERAMIC	C1608 JB 1H 472K-T-A
C34	4030006880	S. CERAMIC	C1608 JB 1H 472K-T-A
C35	4030006880	S. CERAMIC	C1608 JB 1H 472K-T-A
C36	4030006750	S. CERAMIC	C1608 SL 1H 101J-T-A
C37	4030006750	S. CERAMIC	C1608 SL 1H 101J-T-A
C38	4030006750	S. CERAMIC	C1608 SL 1H 101J-T-A
C39	4030006750	S. CERAMIC	C1608 SL 1H 101J-T-A
C40	4030006880	S. CERAMIC	C1608 JB 1H 472K-T-A
C41	4030006880	S. CERAMIC	C1608 JB 1H 472K-T-A
C42	4510003830	ELECTROLYTIC	50 MV R47 SW
C43	4030006880	S. CERAMIC	C1608 JB 1H 472K-T-A
C44	4510004990	ELECTROLYTIC	16 MV 100 HC
C45	4030006880	S. CERAMIC	C1608 JB 1H 472K-T-A
C46	4030008630	S. CERAMIC	C1608 JF 1C 104Z-T-A
C47	4030008630	S. CERAMIC	C1608 JF 1C 104Z-T-A
C48	4030008630	S. CERAMIC	C1608 JF 1C 104Z-T-A
C49	4030008630	S. CERAMIC	C1608 JF 1C 104Z-T-A
DS1	5030000980	LCD	LD-BU5637EZ (E-5806)
DS2	5080000305	LAMP	HRT-3290A-F
DS3	5080000305	LAMP	HRT-3290A-F
DS4	5080000305	LAMP	HRT-3290A-F
S1	2260000080	SWITCH	SKHHAM024A
S2	2260000080	SWITCH	SKHHAM024A
S3	2260000080	SWITCH	SKHHAM024A
S4	2260000080	SWITCH	SKHHAM024A
S5	2260000080	SWITCH	SKHHAM024A [FC]
S6	2260000080	SWITCH	SKHHAM024A [MODE]
S7	2260000080	SWITCH	SKHHAM024A [SCAN]
S8	2260000080	SWITCH	SKHHAM024A [LOCK]
S9	2260000080	SWITCH	SKHHAM024A [RIT]
S10	2260000080	SWITCH	SKHHAM024A [PREAMP/ATT]
S11	2260000080	SWITCH	SKHHAM024A [NB]
S12	2260000080	SWITCH	SKHHAM024A [TUNER]
S13	2260002010	SWITCH	MSR5-2#1 [POWER]

[FRONT UNIT]

REF. NO.	ORDER NO.	DESCRIPTION	
BT1	3020000020	LITHIUM	BR2032-1T2
SP1	2510000670	SPEAKER	VS-50-0827
J1	6510016030	CONNECTOR	52089-1620
J2	6510016030	CONNECTOR	52089-1620
J3	6510016030	CONNECTOR	52089-1620
J5	6510003440	CONNECTOR	B08B-EH-S
J10	6510006060	CONNECTOR	P-422
W2	7120000380	JUMPER	JPW 01 R-01
W3	7120000380	JUMPER	JPW 01 R-01
EP1	0910039463	PCB	B 3859C (FRONT)
EP3	6910007700	E.OTHER	HLJ0999-01-470

[VR UNIT]

REF. NO.	ORDER NO.	DESCRIPTION	
R1	7210001360	VARIABLE	RK097111004NA (10KB) [RIT]
R2	7210001070	VARIABLE	RK0972210001B (10KB/10KA) [SQL/AF]
R3	7310000830	TRIMMER	RV-183 (RH0652C14J0FB) 103
J1	6510003510	CONNECTOR	S03B-EH-S
EP1	0910039441	PCB	B 3862A (VR)

[JACK UNIT]

REF. NO.	ORDER NO.	DESCRIPTION	
R1	7010003280	RESISTOR	ELR20J 100 Ω
R2	7010003280	RESISTOR	ELR20J 100 Ω
J1	6450001250	CONNECTOR	HLJ4306-01-3070 [PHONES]
J3	6510009930	CONNECTOR	PD054-08M
P2	6510003680	CONNECTOR	EHR-08
EP1	0910039432	PCB	B 3863B (JACK)

[MIC BOARD]

REF. NO.	ORDER NO.	DESCRIPTION	
J1	6510000190	CONNECTOR	FM214-8SS (P) [MIC]

S.=Surface mount

[SENSOR BOARD]

REF. NO.	ORDER NO.	DESCRIPTION
S1	2210000210	SWITCH SRBU1C005A [CHANNEL SELECTOR]
J1	6510003520	CONNECTOR S04B-EH-S

[MAIN UNIT]

REF. NO.	ORDER NO.	DESCRIPTION
IC1	1120000970	IC M54562P
IC2	1120002410	S. IC LB1721M-TER
IC3	1130000830	S. IC μPD4094BG-T1
IC5	1130001250	S. IC μPD4066BG-T1
IC6	1110000890	IC μPC1241H
IC7	1120000970	IC M54562P
IC8	1130000830	S. IC μPD4094BG-T1
IC9	1110000960	S. IC NJM4558M (T1)
IC10	1110001320	IC μPC1037HA
IC11	1110001320	IC μPC1037HA
IC13	1130001910	S. IC μPD4011BG-T1
IC14	1110000960	S. IC NJM4558M (T1)
IC15	1110000960	S. IC NJM4558M (T1)
IC16	1110000240	IC BA222-V
IC17	1180000470	IC NJM7808A
IC18	1110002680	S. IC NJM2902M-T1
Q1	1530003150	S. TRANSISTOR 2SC4673D-TD
Q2	1580000600	S. FET 3SK126-O (TE85R)
Q3	1580000600	S. FET 3SK126-O (TE85R)
Q4	1560000560	S. FET 2SK882-GR (TE85L)
Q5	1530003150	S. TRANSISTOR 2SC4673D-TD
Q6	1590000680	S. TRANSISTOR DTC114EU T107
Q7	1590000680	S. TRANSISTOR DTC114EU T107
Q8	1560000560	S. FET 2SK882-GR (TE85L)
Q9	1580000600	S. FET 3SK126-O (TE85R)
Q10	1560000560	S. FET 2SK882-GR (TE85L)
Q11	1510000510	S. TRANSISTOR 2SA1576 T107 R
Q12	1560000560	S. FET 2SK882-GR (TE85L)
Q13	1560000560	S. FET 2SK882-GR (TE85L)
Q14	1590001330	S. TRANSISTOR DTA114EU T107
Q15	1590001330	S. TRANSISTOR DTA114EU T107
Q16	1590000680	S. TRANSISTOR DTC114EU T107
Q17	1520000200	S. TRANSISTOR 2SB798-T2 DK
Q18	1590000680	S. TRANSISTOR DTC114EU T107
Q21	1590000680	S. TRANSISTOR DTC114EU T107
Q22	1560000720	S. FET 2SK2171-4-TD
Q23	1560000720	S. FET 2SK2171-4-TD
Q24	1590001330	S. TRANSISTOR DTA114EU T107
Q25	1530002060	S. TRANSISTOR 2SC4081 T107 R
Q26	1560000720	S. FET 2SK2171-4-TD
Q27	1560000720	S. FET 2SK2171-4-TD
Q28	1580000600	S. FET 3SK126-O (TE85R)
Q29	1590000680	S. TRANSISTOR DTC114EU T107
Q30	1590001330	S. TRANSISTOR DTA114EU T107
Q31	1590000680	S. TRANSISTOR DTC114EU T107
Q32	1590000680	S. TRANSISTOR DTC114EU T107
Q33	1530002060	S. TRANSISTOR 2SC4081 T107 R
Q34	1530002060	S. TRANSISTOR 2SC4081 T107 R
Q35	1530002060	S. TRANSISTOR 2SC4081 T107 R
Q36	1530002060	S. TRANSISTOR 2SC4081 T107 R
Q37	1530002060	S. TRANSISTOR 2SC4081 T107 R
Q38	1590000680	S. TRANSISTOR DTC114EU T107
Q39	1530002060	S. TRANSISTOR 2SC4081 T107 R
Q40	1590001330	S. TRANSISTOR DTA114EU T107
Q41	1590000680	S. TRANSISTOR DTC114EU T107
Q44	1530002060	S. TRANSISTOR 2SC4081 T107 R
Q45	1560000560	S. FET 2SK882-GR (TE85L)
Q46	1580000600	S. FET 3SK126-O (TE85R)

[MAIN UNIT]

REF. NO.	ORDER NO.	DESCRIPTION
Q47	1590000680	S. TRANSISTOR DTC114EU T107
Q48	1530002060	S. TRANSISTOR 2SC4081 T107 R
Q50	1510000510	S. TRANSISTOR 2SA1576 T107 R
Q51	1590000680	S. TRANSISTOR DTC114EU T107
Q52	1540000250	S. TRANSISTOR 2SD999-T2 CK
Q53	1540000250	S. TRANSISTOR 2SD999-T2 CK
Q54	1540000250	S. TRANSISTOR 2SD999-T2 CK
Q55	1590000680	S. TRANSISTOR DTC114EU T107
Q56	1590000680	S. TRANSISTOR DTC114EU T107
Q57	1530003090	S. TRANSISTOR 2SC4213-B (TE85R)
Q58	1530002060	S. TRANSISTOR 2SC4081 T107 R
Q59	1530002060	S. TRANSISTOR 2SC4081 T107 R
Q60	1590000680	S. TRANSISTOR DTC114EU T107
Q61	1590001330	S. TRANSISTOR DTA114EU T107
Q62	1530002060	S. TRANSISTOR 2SC4081 T107 R
Q63	1590000680	S. TRANSISTOR DTC114EU T107
Q64	1530002060	S. TRANSISTOR 2SC4081 T107 R
Q65	1590000680	S. TRANSISTOR DTC114EU T107
Q66	1540000250	S. TRANSISTOR 2SD999-T2 CK
Q67	1530002060	S. TRANSISTOR 2SC4081 T107 R
Q68	1510000510	S. TRANSISTOR 2SA1576 T107 R
Q69	1590000680	S. TRANSISTOR DTC114EU T107
Q70	1590001330	S. TRANSISTOR DTA114EU T107
Q71	1590000680	S. TRANSISTOR DTC114EU T107
Q72	1590001330	S. TRANSISTOR DTA114EU T107
Q73	1540000250	S. TRANSISTOR 2SD999-T2 CK
Q74	1530002060	S. TRANSISTOR 2SC4081 T107 R
Q75	1590000680	S. TRANSISTOR DTC114EU T107
Q76	1530003090	S. TRANSISTOR 2SC4213-B (TE85R)
Q77	1590000680	S. TRANSISTOR DTC114EU T107
D1	1790000450	S. DIODE MA862 (TX)
D2	1790000450	S. DIODE MA862 (TX)
D3	1790000450	S. DIODE MA862 (TX)
D4	1790000450	S. DIODE MA862 (TX)
D5	1790000450	S. DIODE MA862 (TX)
D6	1160000060	S. DIODE DAN202U T107
D7	1160000060	S. DIODE DAN202U T107
D8	1160000060	S. DIODE DAN202U T107
D9	1160000060	S. DIODE DAN202U T107
D10	1790000450	S. DIODE MA862 (TX)
D11	1790000450	S. DIODE MA862 (TX)
D15	1790000690	S. DIODE HSM88ASR-TR
D17	1160000050	S. DIODE DAP202U T107
D18	1160000060	S. DIODE DAN202U T107
D19	1160000050	S. DIODE DAP202U T107
D20	1160000060	S. DIODE DAN202U T107
D21	1160000060	S. DIODE DAN202U T107
D22	1160000050	S. DIODE DAP202U T107
D23	1160000060	S. DIODE DAN202U T107
D24	1160000050	S. DIODE DAP202U T107
D25	1160000060	S. DIODE DAN202U T107
D26	1160000060	S. DIODE DAN202U T107
D31	1160000060	S. DIODE DAN202U T107
D32	1160000060	S. DIODE DAN202U T107
D33	1790000450	S. DIODE MA862 (TX)
D35	1790000450	S. DIODE MA862 (TX)
D36	1790000450	S. DIODE MA862 (TX)
D38	1790000450	S. DIODE MA862 (TX)
D41	1790000450	S. DIODE MA862 (TX)
D42	1790000450	S. DIODE MA862 (TX)
D45	1790000450	S. DIODE MA862 (TX)
D46	1790000450	S. DIODE MA862 (TX)
D49	1790000450	S. DIODE MA862 (TX)
D50	1790000450	S. DIODE MA862 (TX)
D53	1790000450	S. DIODE MA862 (TX)
D55	1790000450	S. DIODE MA862 (TX)
D57	1790000450	S. DIODE MA862 (TX)
D59	1160000060	S. DIODE DAN202U T107
D61	1160000060	S. DIODE DAN202U T107
D62	1160000060	S. DIODE DAN202U T107
D63	1160000050	S. DIODE DAP202U T107
D64	1160000060	S. DIODE DAN202U T107
D65	1790000690	S. DIODE HSM88ASR-TR

S. = Surface mount

[MAIN UNIT]

REF. NO.	ORDER NO.	DESCRIPTION	
D67	1160000060	S. DIODE	DAN202U T107
D68	1160000060	S. DIODE	DAN202U T107
D70	1160000060	S. DIODE	DAN202U T107
D71	1790000690	S. DIODE	HSM88ASR-TR
D72	1160000060	S. DIODE	DAN202U T107
D73	1160000060	S. DIODE	DAN202U T107
D74	1160000060	S. DIODE	DAN202U T107
D76	1160000060	S. DIODE	DAN202U T107
D78	1160000060	S. DIODE	DAN202U T107
D80	1160000060	S. DIODE	DAN202U T107
D81	1160000060	S. DIODE	DAN202U T107
D82	1730000410	S. ZENER	RD5.1M-T2B2
D83	1160000060	S. DIODE	DAN202U T107
D84	1160000050	S. DIODE	DAP202U T107
D85	1160000060	S. DIODE	DAN202U T107
D86	1160000060	S. DIODE	DAN202U T107
D87	1160000060	S. DIODE	DAN202U T107
D88	1160000060	S. DIODE	DAN202U T107
D89	1160000060	S. DIODE	DAN202U T107
D90	1160000060	S. DIODE	DAN202U T107
D91	1790000690	S. DIODE	HSM88ASR-TR
D93	1160000060	S. DIODE	DAN202U T107
D96	1160000060	S. DIODE	DAN202U T107
D97	1160000060	S. DIODE	DAN202U T107
D98	1160000060	S. DIODE	DAN202U T107
D99	1160000060	S. DIODE	DAN202U T107
D100	1160000060	S. DIODE	DAN202U T107
D101	1160000050	S. DIODE	DAP202U T107
D102	1160000050	S. DIODE	DAP202U T107
D104	1160000060	S. DIODE	DAN202U T107
D106	1160000050	S. DIODE	DAP202U T107
D108	1160000060	S. DIODE	DAN202U T107
D110	1160000060	S. DIODE	DAN202U T107
D112	1160000060	S. DIODE	DAN202U T107
D114	1160000060	S. DIODE	DAN202U T107
D115	1160000060	S. DIODE	DAN202U T107
D116	1160000050	S. DIODE	DAP202U T107
D117	1160000050	S. DIODE	DAP202U T107
D118	1160000050	S. DIODE	DAP202U T107
D119	1160000050	S. DIODE	DAP202U T107
D120	1160000050	S. DIODE	DAP202U T107
D121	1160000050	S. DIODE	DAP202U T107
D122	1160000060	S. DIODE	DAN202U T107
D123	1160000060	S. DIODE	DAN202U T107
D124	1790000890	S. DIODE	ND433G
D125	1730000030	S. ZENER	RD5.6M-T2B2
D126	1730000730	S. ZENER	RD6.2M-T2B2
D127	1160000060	S. DIODE	DAN202U T107
D128	1160000060	S. DIODE	DAN202U T107
FI1	2010001590	XTAL	64M15B 64.455000M (FL-197)
FI2	2020000150	CERAMIC	CFW455HT
FI3	2020000210	CERAMIC	CFJ455K5 (FL-65)
L1	6140000080	COIL	LR-20
L2	6180000960	COIL	LAL 03NA 102K
L3	6200003000	S. COIL	NL 322522T-R22J-3
L4	6200003010	S. COIL	NL 322522T-R27J-3
L5	6200001850	S. COIL	NL 322522T-5R6J
L6	6140002050	COIL	LR-224
L7	6150001770	COIL	LS-198
L8	6150000990	COIL	LS-114
L9	6200003260	S. COIL	NL 322522T-101J
L10	6200003030	S. COIL	NL 322522T-R47J-3
L11	6200003000	S. COIL	NL 322522T-R22J-3
L12	6200003260	S. COIL	NL 322522T-101J
L13	6150002430	COIL	LS-254
L14	6150002430	COIL	LS-254
L15	6140002060	COIL	LR-225
L16	6140002510	COIL	LR-289
L17	6150004090	COIL	LS-469 (C-13969)
L18	6200003260	S. COIL	NL 322522T-101J

[MAIN UNIT]

REF. NO.	ORDER NO.	DESCRIPTION	
L19	6150004080	COIL	LS-468 (C-13958)
L20	6150004080	COIL	LS-468 (C-13958)
L21	6150004080	COIL	LS-468 (C-13958)
L22	6180000960	COIL	LAL 03NA 102K
L23	6150002290	COIL	LS-240
L24	6150002290	COIL	LS-240
L25	6180002250	COIL	LAL 03NA 331K
L27	6200003260	S. COIL	NL 322522T-101J
L28	6200001850	S. COIL	NL 322522T-5R6J
L29	6200003110	S. COIL	NL 322522T-6R8J
L30	6200003260	S. COIL	NL 322522T-101J
L31	6200003260	S. COIL	NL 322522T-101J
L32	6200003260	S. COIL	NL 322522T-101J
L33	6200002960	S. COIL	NL 322522T-4R7J-3
L34	6200003320	S. COIL	NL 322522T-3R3J-3
L35	6200003260	S. COIL	NL 322522T-101J
L36	6200003090	S. COIL	NL 322522T-2R7J-3
L37	6200003100	S. COIL	NL 322522T-3R9J-3
L38	6180002860	COIL	EL0606SKI-4R7J
L39	6200001850	S. COIL	NL 322522T-5R6J
L40	6200003260	S. COIL	NL 322522T-101J
L41	6200002990	S. COIL	NL 322522T-4R2J-3
L42	6200002990	S. COIL	NL 322522T-2R2J-3
L43	6200003260	S. COIL	NL 322522T-101J
L44	6200003050	S. COIL	NL 322522T-R82J-3
L45	6200003060	S. COIL	NL 322522T-1R2J-3
L46	6200003080	S. COIL	NL 322522T-1R8J-3
L47	6200003070	S. COIL	NL 322522T-1R5J-3
L48	6200003260	S. COIL	NL 322522T-101J
L49	6200003060	S. COIL	NL 322522T-1R2J-3
L50	6200003330	S. COIL	NL 322522T-1R0J-3
L51	6200003050	S. COIL	NL 322522T-R82J-3
L52	6200003060	S. COIL	NL 322522T-1R2J-3
L53	6200003260	S. COIL	NL 322522T-101J
L54	6200003030	S. COIL	NL 322522T-R47J-3
L55	6200002980	S. COIL	NL 322522T-R56J-3
L56	6200003040	S. COIL	NL 322522T-R68J-3
L57	6200003050	S. COIL	NL 322522T-R82J-3
L58	6200003260	S. COIL	NL 322522T-101J
L59	6200003250	S. COIL	NL 322522T-R39J-3
L60	6200003250	S. COIL	NL 322522T-R39J-3
L61	6200003030	S. COIL	NL 322522T-R47J-3
L62	6200002980	S. COIL	NL 322522T-R56J-3
L63	6200003260	S. COIL	NL 322522T-101J
L64	6200003010	S. COIL	NL 322522T-R27J-3
L65	6200003010	S. COIL	NL 322522T-R27J-3
L66	6200003020	S. COIL	NL 322522T-R33J-3
L67	6200003250	S. COIL	NL 322522T-R39J-3
L68	6140000640	COIL	LR-86
L69	6140001540	COIL	LR-169
L70	6110001650	COIL	LA-248
L71	6200003010	S. COIL	NL 322522T-R27J-3
L72	6140002050	COIL	LR-224
L73	6110001650	COIL	LA-248
L74	6200003140	S. COIL	NL 322522T-150J
L75	6150001770	COIL	LS-198
L76	6150002430	COIL	LS-254
L77	6150002430	COIL	LS-254
L78	6150000990	COIL	LS-114
L79	6170000140	COIL	LW-15
L80	6150002291	COIL	LS-450
L81	6150002271	COIL	LS-451
L82	6150002291	COIL	LS-450
L83	6180000960	COIL	LAL 03NA 102K
L84	6180000960	COIL	LAL 03NA 102K
L86	6180000960	COIL	LAL 03NA 102K
L87	6180000960	COIL	LAL 03NA 102K
L88	6910003570	COIL	2943-666663
L89	6910003570	COIL	2943-666663
L90	6910000670	COIL	BT01RN1-A61-001
L91	6180000960	COIL	LAL 03NA 102K
L92	6180000960	COIL	LAL 03NA 102K
L94	6200003260	S. COIL	NL 322522T-101J
L95	6200003260	S. COIL	NL 322522T-101J
L96	6200003260	S. COIL	NL 322522T-101J

S. = Surface mount

[MAIN UNIT]

REF. NO.	ORDER NO.	DESCRIPTION	
L97	6910000670	COIL	BT01RN1-A61-001
L98	6910000670	COIL	BT01RN1-A61-001
L99	6200003260	S. COIL	NL 322522T-101J
L100	6200003260	S. COIL	NL 322522T-101J
L102	6910000670	COIL	BT01RN1-A61-001
L103	6200003260	S. COIL	NL 322522T-101J
L104	6200003260	S. COIL	NL 322522T-101J
L105	6910000670	COIL	BT01RN1-A61-001
L106	6200003260	S. COIL	NL 322522T-101J
L107	6180002190	COIL	LAL 02NA R47K
L108	6180000690	COIL	LAL 03NA R22M
R1	7030003380	S. RESISTOR	ERJ3GEYJ 331 V (330 Ω)
R2	7030003220	S. RESISTOR	ERJ3GEYJ 150 V (15 Ω)
R3	7030003380	S. RESISTOR	ERJ3GEYJ 331 V (330 Ω)
R4	7030003280	S. RESISTOR	ERJ3GEYJ 470 V (47 Ω)
R5	7030003550	S. RESISTOR	ERJ3GEYJ 822 V (8.2 kΩ)
R6	7030004040	S. RESISTOR	ERJ3GEYJ 4R7 V (4.7 Ω)
R7	7030003460	S. RESISTOR	ERJ3GEYJ 152 V (1.5 kΩ)
R8	7030003290	S. RESISTOR	ERJ3GEYJ 560 V (56 Ω)
R9	7030003680	S. RESISTOR	ERJ3GEYJ 104 V (100 kΩ)
R10	7030003680	S. RESISTOR	ERJ3GEYJ 104 V (100 kΩ)
R11	7030003680	S. RESISTOR	ERJ3GEYJ 104 V (100 kΩ)
R12	7030003600	S. RESISTOR	ERJ3GEYJ 223 V (22 kΩ)
R13	7030003560	S. RESISTOR	ERJ3GEYJ 103 V (10 kΩ)
R14	7030003520	S. RESISTOR	ERJ3GEYJ 472 V (4.7 kΩ)
R15	7030003320	S. RESISTOR	ERJ3GEYJ 101 V (100 Ω)
R16	7030003340	S. RESISTOR	ERJ3GEYJ 151 V (150 Ω)
R17	7030003500	S. RESISTOR	ERJ3GEYJ 332 V (3.3 kΩ)
R18	7030003290	S. RESISTOR	ERJ3GEYJ 560 V (56 Ω)
R19	7030003440	S. RESISTOR	ERJ3GEYJ 102 V (1 kΩ)
R20	7030003530	S. RESISTOR	ERJ3GEYJ 562 V (5.6 kΩ)
R21	7030003200	S. RESISTOR	ERJ3GEYJ 100 V (10 Ω)
R22	7030003420	S. RESISTOR	ERJ3GEYJ 681 V (680 Ω)
R23	7030003290	S. RESISTOR	ERJ3GEYJ 560 V (56 Ω)
R24	7030003280	S. RESISTOR	ERJ3GEYJ 470 V (47 Ω)
R25	7030003480	S. RESISTOR	ERJ3GEYJ 222 V (2.2 kΩ)
R26	7030003480	S. RESISTOR	ERJ3GEYJ 222 V (2.2 kΩ)
R27	7030003480	S. RESISTOR	ERJ3GEYJ 222 V (2.2 kΩ)
R28	7030003520	S. RESISTOR	ERJ3GEYJ 472 V (4.7 kΩ)
R29	7030003520	S. RESISTOR	ERJ3GEYJ 472 V (4.7 kΩ)
R30	7030003480	S. RESISTOR	ERJ3GEYJ 222 V (2.2 kΩ)
R31	7030003380	S. RESISTOR	ERJ3GEYJ 331 V (330 Ω)
R32	7030003220	S. RESISTOR	ERJ3GEYJ 150 V (15 Ω)
R33	7030003380	S. RESISTOR	ERJ3GEYJ 331 V (330 Ω)
R34	7030003440	S. RESISTOR	ERJ3GEYJ 102 V (1 kΩ)
R35	7030003400	S. RESISTOR	ERJ3GEYJ 471 V (470 Ω)
R36	7310002760	S. TRIMMER	RV-152 (RH03A3AJ4X0HA) 223
R37	7030003320	S. RESISTOR	ERJ3GEYJ 101 V (100 Ω)
R38	7030003560	S. RESISTOR	ERJ3GEYJ 103 V (10 kΩ)
R39	7030003800	S. RESISTOR	ERJ3GEYJ 105 V (1 MΩ)
R40	7030003400	S. RESISTOR	ERJ3GEYJ 471 V (470 Ω)
R41	7510000260	THERMISTOR	ERT-D2ZGL 102S
R42	7030003560	S. RESISTOR	ERJ3GEYJ 103 V (10 kΩ)
R43	7030003560	S. RESISTOR	ERJ3GEYJ 103 V (10 kΩ)
R44	7030003400	S. RESISTOR	ERJ3GEYJ 471 V (470 Ω)
R45	7030003440	S. RESISTOR	ERJ3GEYJ 102 V (1 kΩ)
R46	7030003400	S. RESISTOR	ERJ3GEYJ 471 V (470 Ω)
R47	7030003360	S. RESISTOR	ERJ3GEYJ 221 V (220 Ω)
R48	7030003520	S. RESISTOR	ERJ3GEYJ 472 V (4.7 kΩ)
R49	7030003470	S. RESISTOR	ERJ3GEYJ 182 V (1.8 kΩ)
R50	7030003760	S. RESISTOR	ERJ3GEYJ 474 V (470 kΩ)
R51	7030003360	S. RESISTOR	ERJ3GEYJ 221 V (220 Ω)
R52	7030003320	S. RESISTOR	ERJ3GEYJ 101 V (100 Ω)
R53	7030003540	S. RESISTOR	ERJ3GEYJ 682 V (6.8 kΩ)
R54	7030003280	S. RESISTOR	ERJ3GEYJ 470 V (47 Ω)
R55	7030003640	S. RESISTOR	ERJ3GEYJ 473 V (47 kΩ)
R56	7030003400	S. RESISTOR	ERJ3GEYJ 471 V (470 Ω)
R57	7030003320	S. RESISTOR	ERJ3GEYJ 101 V (100 Ω)
R58	7030003600	S. RESISTOR	ERJ3GEYJ 223 V (22 kΩ)
R59	7030003680	S. RESISTOR	ERJ3GEYJ 104 V (100 kΩ)
R60	7030003380	S. RESISTOR	ERJ3GEYJ 331 V (330 Ω)
R61	7030003400	S. RESISTOR	ERJ3GEYJ 471 V (470 Ω)

[MAIN UNIT]

REF. NO.	ORDER NO.	DESCRIPTION	
R62	7030003320	S. RESISTOR	ERJ3GEYJ 101 V (100 Ω)
R63	7030003520	S. RESISTOR	ERJ3GEYJ 472 V (4.7 kΩ)
R64	7030003640	S. RESISTOR	ERJ3GEYJ 473 V (47 kΩ)
R65	7030003400	S. RESISTOR	ERJ3GEYJ 471 V (470 Ω)
R66	7030003440	S. RESISTOR	ERJ3GEYJ 102 V (1 kΩ)
R67	7030003320	S. RESISTOR	ERJ3GEYJ 101 V (100 Ω)
R68	7010004450	RESISTOR	R20J 100 kΩ
R69	7030003520	S. RESISTOR	ERJ3GEYJ 472 V (4.7 kΩ)
R70	7030003560	S. RESISTOR	ERJ3GEYJ 103 V (10 kΩ)
R71	7030003530	S. RESISTOR	ERJ3GEYJ 562 V (5.6 kΩ)
R72	7030003320	S. RESISTOR	ERJ3GEYJ 101 V (100 Ω)
R73	7030003560	S. RESISTOR	ERJ3GEYJ 103 V (10 kΩ)
R74	7030003440	S. RESISTOR	ERJ3GEYJ 102 V (1 kΩ)
R75	7030003560	S. RESISTOR	ERJ3GEYJ 103 V (10 kΩ)
R76	7030003530	S. RESISTOR	ERJ3GEYJ 562 V (5.6 kΩ)
R77	7030003320	S. RESISTOR	ERJ3GEYJ 101 V (100 Ω)
R78	7030003560	S. RESISTOR	ERJ3GEYJ 103 V (10 kΩ)
R79	7030003560	S. RESISTOR	ERJ3GEYJ 103 V (10 kΩ)
R80	7030003500	S. RESISTOR	ERJ3GEYJ 332 V (3.3 kΩ)
R81	7030003530	S. RESISTOR	ERJ3GEYJ 562 V (5.6 kΩ)
R82	7030003320	S. RESISTOR	ERJ3GEYJ 101 V (100 Ω)
R83	7030003500	S. RESISTOR	ERJ3GEYJ 332 V (3.3 kΩ)
R84	7030003560	S. RESISTOR	ERJ3GEYJ 103 V (10 kΩ)
R85	7030003620	S. RESISTOR	ERJ3GEYJ 333 V (33 kΩ)
R86	7030003620	S. RESISTOR	ERJ3GEYJ 333 V (33 kΩ)
R87	7030003380	S. RESISTOR	ERJ3GEYJ 331 V (330 Ω)
R88	7030003220	S. RESISTOR	ERJ3GEYJ 150 V (15 Ω)
R89	7030003380	S. RESISTOR	ERJ3GEYJ 331 V (330 Ω)
R90	7030003480	S. RESISTOR	ERJ3GEYJ 222 V (2.2 kΩ)
R91	7030003380	S. RESISTOR	ERJ3GEYJ 331 V (330 Ω)
R92	7030003220	S. RESISTOR	ERJ3GEYJ 150 V (15 Ω)
R93	7030003380	S. RESISTOR	ERJ3GEYJ 331 V (330 Ω)
R94	7030003480	S. RESISTOR	ERJ3GEYJ 222 V (2.2 kΩ)
R95	7030003520	S. RESISTOR	ERJ3GEYJ 472 V (4.7 kΩ)
R96	7010003830	RESISTOR	R20J 1 Ω
R97	7010003280	RESISTOR	ELR20J 100 Ω
R98	7030003520	S. RESISTOR	ERJ3GEYJ 472 V (4.7 kΩ)
R99	7030003390	S. RESISTOR	ERJ3GEYJ 391 V (390 Ω)
R100	7030003290	S. RESISTOR	ERJ3GEYJ 560 V (56 Ω)
R102	7030003400	S. RESISTOR	ERJ3GEYJ 471 V (470 Ω)
R103	7030003640	S. RESISTOR	ERJ3GEYJ 473 V (47 kΩ)
R104	7030003640	S. RESISTOR	ERJ3GEYJ 473 V (47 kΩ)
R105	7030003240	S. RESISTOR	ERJ3GEYJ 220 V (22 Ω)
R106	7030003280	S. RESISTOR	ERJ3GEYJ 470 V (47 Ω)
R107	7030003400	S. RESISTOR	ERJ3GEYJ 471 V (470 Ω)
R108	7030003240	S. RESISTOR	ERJ3GEYJ 220 V (22 Ω)
R109	7030003400	S. RESISTOR	ERJ3GEYJ 471 V (470 Ω)
R110	7030003640	S. RESISTOR	ERJ3GEYJ 473 V (47 kΩ)
R111	7030003640	S. RESISTOR	ERJ3GEYJ 473 V (47 kΩ)
R112	7030003640	S. RESISTOR	ERJ3GEYJ 473 V (47 kΩ)
R113	7030003640	S. RESISTOR	ERJ3GEYJ 473 V (47 kΩ)
R114	7030003400	S. RESISTOR	ERJ3GEYJ 471 V (470 Ω)
R115	7030003400	S. RESISTOR	ERJ3GEYJ 471 V (470 Ω)
R116	7030003400	S. RESISTOR	ERJ3GEYJ 471 V (470 Ω)
R117	7030003480	S. RESISTOR	ERJ3GEYJ 222 V (2.2 kΩ)
R118	7030003480	S. RESISTOR	ERJ3GEYJ 222 V (2.2 kΩ)
R119	7030003480	S. RESISTOR	ERJ3GEYJ 222 V (2.2 kΩ)
R120	7030003480	S. RESISTOR	ERJ3GEYJ 222 V (2.2 kΩ)
R121	7030003480	S. RESISTOR	ERJ3GEYJ 222 V (2.2 kΩ)
R122	7030003480	S. RESISTOR	ERJ3GEYJ 222 V (2.2 kΩ)
R123	7030003480	S. RESISTOR	ERJ3GEYJ 222 V (2.2 kΩ)
R124	7030003480	S. RESISTOR	ERJ3GEYJ 222 V (2.2 kΩ)
R125	7030003400	S. RESISTOR	ERJ3GEYJ 471 V (470 Ω)
R126	7030003400	S. RESISTOR	ERJ3GEYJ 471 V (470 Ω)
R127	7030003400	S. RESISTOR	ERJ3GEYJ 471 V (470 Ω)
R128	7030003400	S. RESISTOR	ERJ3GEYJ 471 V (470 Ω)
R129	7030003400	S. RESISTOR	ERJ3GEYJ 471 V (470 Ω)
R130	7030003400	S. RESISTOR	ERJ3GEYJ 471 V (470 Ω)
R131	7030003400	S. RESISTOR	ERJ3GEYJ 471 V (470 Ω)
R132	7030003400	S. RESISTOR	ERJ3GEYJ 471 V (470 Ω)
R133	7030003400	S. RESISTOR	ERJ3GEYJ 471 V (470 Ω)
R134	7030003400	S. RESISTOR	ERJ3GEYJ 471 V (470 Ω)
R135	7030003440	S. RESISTOR	ERJ3GEYJ 102 V (1 kΩ)
R136	7030003440	S. RESISTOR	ERJ3GEYJ 102 V (1 kΩ)
R137	7030003440	S. RESISTOR	ERJ3GEYJ 102 V (1 kΩ)

S.=Surface mount

[MAIN UNIT]

REF. NO.	ORDER NO.	DESCRIPTION	
R138	7030003640	S. RESISTOR	ERJ3GEYJ 473 V (47 kΩ)
R139	7030003640	S. RESISTOR	ERJ3GEYJ 473 V (47 kΩ)
R140	7030003640	S. RESISTOR	ERJ3GEYJ 473 V (47 kΩ)
R141	7030003400	S. RESISTOR	ERJ3GEYJ 471 V (470 Ω)
R142	7030003240	S. RESISTOR	ERJ3GEYJ 220 V (22 Ω)
R143	7030003360	S. RESISTOR	ERJ3GEYJ 221 V (220 Ω)
R144	7030003360	S. RESISTOR	ERJ3GEYJ 221 V (220 Ω)
R145	7030004040	S. RESISTOR	ERJ3GEYJ 4R7 V (4.7 Ω)
R146	7030003440	S. RESISTOR	ERJ3GEYJ 102 V (1 kΩ)
R147	7030003440	S. RESISTOR	ERJ3GEYJ 102 V (1 kΩ)
R148	7030003400	S. RESISTOR	ERJ3GEYJ 471 V (470 Ω)
R149	7030003400	S. RESISTOR	ERJ3GEYJ 471 V (470 Ω)
R150	7030003440	S. RESISTOR	ERJ3GEYJ 102 V (1 kΩ)
R151	7030003560	S. RESISTOR	ERJ3GEYJ 103 V (10 kΩ)
R152	7030003280	S. RESISTOR	ERJ3GEYJ 470 V (47 Ω)
R153	7030003480	S. RESISTOR	ERJ3GEYJ 222 V (2.2 kΩ)
R154	7030003480	S. RESISTOR	ERJ3GEYJ 222 V (2.2 kΩ)
R155	7030003520	S. RESISTOR	ERJ3GEYJ 472 V (4.7 kΩ)
R156	7030003240	S. RESISTOR	ERJ3GEYJ 220 V (22 Ω)
R157	7030003470	S. RESISTOR	ERJ3GEYJ 182 V (1.8 kΩ)
R158	7030003800	S. RESISTOR	ERJ3GEYJ 105 V (1 MΩ)
R159	7030003320	S. RESISTOR	ERJ3GEYJ 101 V (100 Ω)
R160	7030003480	S. RESISTOR	ERJ3GEYJ 222 V (2.2 kΩ)
R161	7030003520	S. RESISTOR	ERJ3GEYJ 472 V (4.7 kΩ)
R162	7030003760	S. RESISTOR	ERJ3GEYJ 474 V (470 kΩ)
R163	7030003600	S. RESISTOR	ERJ3GEYJ 223 V (22 kΩ)
R164	7030003640	S. RESISTOR	ERJ3GEYJ 473 V (47 kΩ)
R165	7030003560	S. RESISTOR	ERJ3GEYJ 103 V (10 kΩ)
R166	7030003840	S. RESISTOR	ERJ3GEYJ 225 V (2.2 MΩ)
R167	7030003800	S. RESISTOR	ERJ3GEYJ 105 V (1 MΩ)
R168	7030003560	S. RESISTOR	ERJ3GEYJ 103 V (10 kΩ)
R169	7030003560	S. RESISTOR	ERJ3GEYJ 103 V (10 kΩ)
R170	7030003320	S. RESISTOR	ERJ3GEYJ 101 V (100 Ω)
R171	7030003520	S. RESISTOR	ERJ3GEYJ 472 V (4.7 kΩ)
R172	7510000320	THERMISTOR	ERT-D2ZGL 202S
R173	7030003800	S. RESISTOR	ERJ3GEYJ 105 V (1 MΩ)
R174	7030003550	S. RESISTOR	ERJ3GEYJ 822 V (8.2 kΩ)
R175	7310002740	S. TRIMMER	RV-150 (RH03A3A14X0FC) 103
R176	7030003540	S. RESISTOR	ERJ3GEYJ 682 V (6.8 kΩ)
R177	7030003440	S. RESISTOR	ERJ3GEYJ 102 V (1 kΩ)
R178	7030003520	S. RESISTOR	ERJ3GEYJ 472 V (4.7 kΩ)
R179	7030003520	S. RESISTOR	ERJ3GEYJ 472 V (4.7 kΩ)
R180	7310000780	TRIMMER	RH0651CS4J25A (47K)
R181	7030003520	S. RESISTOR	ERJ3GEYJ 472 V (4.7 kΩ)
R182	7030003440	S. RESISTOR	ERJ3GEYJ 102 V (1 kΩ)
R183	7030003440	S. RESISTOR	ERJ3GEYJ 102 V (1 kΩ)
R184	7030003620	S. RESISTOR	ERJ3GEYJ 333 V (33 kΩ)
R185	7030003480	S. RESISTOR	ERJ3GEYJ 222 V (2.2 kΩ)
R186	7030003440	S. RESISTOR	ERJ3GEYJ 102 V (1 kΩ)
R187	7030003320	S. RESISTOR	ERJ3GEYJ 101 V (100 Ω)
R188	7030003680	S. RESISTOR	ERJ3GEYJ 104 V (100 kΩ)
R189	7030003240	S. RESISTOR	ERJ3GEYJ 220 V (22 Ω)
R190	7030003680	S. RESISTOR	ERJ3GEYJ 104 V (100 kΩ)
R191	7030003680	S. RESISTOR	ERJ3GEYJ 104 V (100 kΩ)
R192	7030003680	S. RESISTOR	ERJ3GEYJ 104 V (100 kΩ)
R193	7030003680	S. RESISTOR	ERJ3GEYJ 104 V (100 kΩ)
R194	7030003480	S. RESISTOR	ERJ3GEYJ 222 V (2.2 kΩ)
R195	7030003590	S. RESISTOR	ERJ3GEYJ 183 V (18 kΩ)
R196	7030003590	S. RESISTOR	ERJ3GEYJ 183 V (18 kΩ)
R197	7030003570	S. RESISTOR	ERJ3GEYJ 123 V (12 kΩ)
R198	7030003440	S. RESISTOR	ERJ3GEYJ 102 V (1 kΩ)
R199	7030003500	S. RESISTOR	ERJ3GEYJ 332 V (3.3 kΩ)
R200	7030003660	S. RESISTOR	ERJ3GEYJ 683 V (68 kΩ)
R201	7030003440	S. RESISTOR	ERJ3GEYJ 102 V (1 kΩ)
R202	7030003680	S. RESISTOR	ERJ3GEYJ 104 V (100 kΩ)
R203	7030003280	S. RESISTOR	ERJ3GEYJ 470 V (47 Ω)
R204	7030003280	S. RESISTOR	ERJ3GEYJ 470 V (47 Ω)
R205	7030004050	S. RESISTOR	ERJ3GEYJ 1R0 V (1 Ω)
R206	7010003100	RESISTOR	ELR20J 3.3 Ω
R207	7030003440	S. RESISTOR	ERJ3GEYJ 102 V (1 kΩ)
R208	7030003440	S. RESISTOR	ERJ3GEYJ 102 V (1 kΩ)
R209	7030003560	S. RESISTOR	ERJ3GEYJ 103 V (10 kΩ)
R210	7030003560	S. RESISTOR	ERJ3GEYJ 103 V (10 kΩ)
R211	7030003560	S. RESISTOR	ERJ3GEYJ 103 V (10 kΩ)

[MAIN UNIT]

REF. NO.	ORDER NO.	DESCRIPTION	
R212	7030003440	S. RESISTOR	ERJ3GEYJ 102 V (1 kΩ)
R213	7030003560	S. RESISTOR	ERJ3GEYJ 103 V (10 kΩ)
R214	7030003560	S. RESISTOR	ERJ3GEYJ 103 V (10 kΩ)
R215	7030003640	S. RESISTOR	ERJ3GEYJ 473 V (47 kΩ)
R216	7030003380	S. RESISTOR	ERJ3GEYJ 331 V (330 Ω)
R217	7030003540	S. RESISTOR	ERJ3GEYJ 682 V (6.8 kΩ)
R218	7030003600	S. RESISTOR	ERJ3GEYJ 223 V (22 kΩ)
R219	7030003360	S. RESISTOR	ERJ3GEYJ 221 V (220 Ω)
R220	7030003480	S. RESISTOR	ERJ3GEYJ 222 V (2.2 kΩ)
R221	7010003830	RESISTOR	R20J 1 Ω
R222	7030003280	S. RESISTOR	ERJ3GEYJ 470 V (47 Ω)
R223	7030003320	S. RESISTOR	ERJ3GEYJ 101 V (100 Ω)
R224	7030003610	S. RESISTOR	ERJ3GEYJ 273 V (27 kΩ)
R225	7030003400	S. RESISTOR	ERJ3GEYJ 471 V (470 Ω)
R226	7030003640	S. RESISTOR	ERJ3GEYJ 473 V (47 kΩ)
R227	7030003320	S. RESISTOR	ERJ3GEYJ 101 V (100 Ω)
R228	7510000240	THERMISTOR	ERT-D2ZGL 332S
R229	7030003560	S. RESISTOR	ERJ3GEYJ 103 V (10 kΩ)
R230	7310002720	S. TRIMMER	RV-148 (RH03A3A3X0DA) 472
R231	7030003320	S. RESISTOR	ERJ3GEYJ 101 V (100 Ω)
R232	7030003380	S. RESISTOR	ERJ3GEYJ 331 V (330 Ω)
R233	7030003400	S. RESISTOR	ERJ3GEYJ 471 V (470 Ω)
R234	7030003760	S. RESISTOR	ERJ3GEYJ 474 V (470 kΩ)
R235	7030003720	S. RESISTOR	ERJ3GEYJ 224 V (220 kΩ)
R236	7030003560	S. RESISTOR	ERJ3GEYJ 103 V (10 kΩ)
R237	7030003520	S. RESISTOR	ERJ3GEYJ 472 V (4.7 kΩ)
R238	7030003520	S. RESISTOR	ERJ3GEYJ 472 V (4.7 kΩ)
R239	7030003520	S. RESISTOR	ERJ3GEYJ 472 V (4.7 kΩ)
R240	7030003520	S. RESISTOR	ERJ3GEYJ 472 V (4.7 kΩ)
R241	7030003520	S. RESISTOR	ERJ3GEYJ 472 V (4.7 kΩ)
R242	7030003520	S. RESISTOR	ERJ3GEYJ 472 V (4.7 kΩ)
R243	7030003520	S. RESISTOR	ERJ3GEYJ 472 V (4.7 kΩ)
R244	7030003480	S. RESISTOR	ERJ3GEYJ 222 V (2.2 kΩ)
R245	7030003440	S. RESISTOR	ERJ3GEYJ 102 V (1 kΩ)
R246	7030003440	S. RESISTOR	ERJ3GEYJ 102 V (1 kΩ)
R247	7030003440	S. RESISTOR	ERJ3GEYJ 102 V (1 kΩ)
R248	7030003640	S. RESISTOR	ERJ3GEYJ 473 V (47 kΩ)
R249	7030003640	S. RESISTOR	ERJ3GEYJ 473 V (47 kΩ)
R250	7030003450	S. RESISTOR	ERJ3GEYJ 122 V (1.2 kΩ)
R251	7310002740	S. TRIMMER	RV-150 (RH03A3A14X0FC) 103
R252	7030003680	S. RESISTOR	ERJ3GEYJ 104 V (100 kΩ)
R253	7310002740	S. TRIMMER	RV-150 (RH03A3A14X0FC) 103
R254	7030003720	S. RESISTOR	ERJ3GEYJ 224 V (220 kΩ)
R255	7030003560	S. RESISTOR	ERJ3GEYJ 103 V (10 kΩ)
R256	7030003320	S. RESISTOR	ERJ3GEYJ 101 V (100 Ω)
R257	7030003560	S. RESISTOR	ERJ3GEYJ 103 V (10 kΩ)
R258	7030003560	S. RESISTOR	ERJ3GEYJ 103 V (10 kΩ)
R259	7030003290	S. RESISTOR	ERJ3GEYJ 560 V (56 Ω)
R260	7030003680	S. RESISTOR	ERJ3GEYJ 104 V (100 kΩ)
R261	7030003560	S. RESISTOR	ERJ3GEYJ 103 V (10 kΩ)
R262	7030003280	S. RESISTOR	ERJ3GEYJ 470 V (47 Ω)
R263	7010004410	RESISTOR	R20J 47 kΩ
R264	7030003800	S. RESISTOR	ERJ3GEYJ 105 V (1 MΩ)
R265	7030003580	S. RESISTOR	ERJ3GEYJ 153 V (15 kΩ)
R266	7030003400	S. RESISTOR	ERJ3GEYJ 471 V (470 Ω)
R267	7010004320	RESISTOR	R20J 10 kΩ
R268	7310002580	S. TRIMMER	RV-108 (RH03A3A15X05A) 104
R269	7030003640	S. RESISTOR	ERJ3GEYJ 473 V (47 kΩ)
R270	7030003640	S. RESISTOR	ERJ3GEYJ 473 V (47 kΩ)
R271	7030003730	S. RESISTOR	ERJ3GEYJ 274 V (270 kΩ)
R272	7030003440	S. RESISTOR	ERJ3GEYJ 102 V (1 kΩ)
R273	7030003640	S. RESISTOR	ERJ3GEYJ 473 V (47 kΩ)
R274	7030003520	S. RESISTOR	ERJ3GEYJ 472 V (4.7 kΩ)
R275	7030003400	S. RESISTOR	ERJ3GEYJ 471 V (470 Ω)
R276	7310002580	S. TRIMMER	RV-108 (RH03A3A15X05A) 104
R278	7030003520	S. RESISTOR	ERJ3GEYJ 472 V (4.7 kΩ)
R279	7030003730	S. RESISTOR	ERJ3GEYJ 274 V (270 kΩ)
R280	7030003840	S. RESISTOR	ERJ3GEYJ 225 V (2.2 MΩ)
R281	7030003400	S. RESISTOR	ERJ3GEYJ 471 V (470 Ω)
R282	7030003440	S. RESISTOR	ERJ3GEYJ 102 V (1 kΩ)

S.=Surface mount

[MAIN UNIT]

REF. NO.	ORDER NO.	DESCRIPTION	
R283	7030003290	S. RESISTOR	ERJ3GEYJ 560 V (56 Ω)
R284	7030003400	S. RESISTOR	ERJ3GEYJ 471 V (470 Ω)
R285	7310002740	S. TRIMMER	RV-150 (RH03A3A14X0FC) 103
R286	7030003620	S. RESISTOR	ERJ3GEYJ 333 V (33 kΩ)
R287	7030003620	S. RESISTOR	ERJ3GEYJ 333 V (33 kΩ)
R288	7030003800	S. RESISTOR	ERJ3GEYJ 105 V (1 MΩ)
R289	7030003640	S. RESISTOR	ERJ3GEYJ 473 V (47 kΩ)
R290	7030003640	S. RESISTOR	ERJ3GEYJ 473 V (47 kΩ)
R291	7030003400	S. RESISTOR	ERJ3GEYJ 471 V (470 Ω)
R292	7030003560	S. RESISTOR	ERJ3GEYJ 103 V (10 kΩ)
R293	7030003680	S. RESISTOR	ERJ3GEYJ 104 V (100 kΩ)
R294	7010003910	RESISTOR	R20J 4.7 Ω
R295	7010004190	RESISTOR	R20J 1 kΩ
R296	7010003910	RESISTOR	R20J 4.7 Ω
R297	7010004190	RESISTOR	R20J 1 kΩ
R298	7010003910	RESISTOR	R20J 4.7 Ω
R299	7030003480	S. RESISTOR	ERJ3GEYJ 222 V (2.2 kΩ)
R300	7310002740	S. TRIMMER	RV-150 (RH03A3A14X0FC) 103
R301	7030003600	S. RESISTOR	ERJ3GEYJ 223 V (22 kΩ)
R302	7030003520	S. RESISTOR	ERJ3GEYJ 472 V (4.7 kΩ)
R303	7030003440	S. RESISTOR	ERJ3GEYJ 102 V (1 kΩ)
R304	7030003700	S. RESISTOR	ERJ3GEYJ 154 V (150 kΩ)
R305	7030003720	S. RESISTOR	ERJ3GEYJ 224 V (220 kΩ)
R306	7030003360	S. RESISTOR	ERJ3GEYJ 221 V (220 Ω)
R307	7030003520	S. RESISTOR	ERJ3GEYJ 472 V (4.7 kΩ)
R308	7030003600	S. RESISTOR	ERJ3GEYJ 223 V (22 kΩ)
R310	7030003440	S. RESISTOR	ERJ3GEYJ 102 V (1 kΩ)
R311	7030003510	S. RESISTOR	ERJ3GEYJ 392 V (3.9 kΩ)
R312	7030003630	S. RESISTOR	ERJ3GEYJ 393 V (39 kΩ)
R313	7030003580	S. RESISTOR	ERJ3GEYJ 153 V (15 kΩ)
R314	7030003520	S. RESISTOR	ERJ3GEYJ 472 V (4.7 kΩ)
R315	7030003760	S. RESISTOR	ERJ3GEYJ 474 V (470 kΩ)
R316	7030003560	S. RESISTOR	ERJ3GEYJ 103 V (10 kΩ)
R317	7030003760	S. RESISTOR	ERJ3GEYJ 474 V (470 kΩ)
R318	7030003440	S. RESISTOR	ERJ3GEYJ 102 V (1 kΩ)
R319	7030003560	S. RESISTOR	ERJ3GEYJ 103 V (10 kΩ)
R320	7030003360	S. RESISTOR	ERJ3GEYJ 221 V (220 Ω)
R321	7030003520	S. RESISTOR	ERJ3GEYJ 472 V (4.7 kΩ)
R322	7030003520	S. RESISTOR	ERJ3GEYJ 472 V (4.7 kΩ)
R323	7030003530	S. RESISTOR	ERJ3GEYJ 562 V (5.6 kΩ)
R324	7030003550	S. RESISTOR	ERJ3GEYJ 822 V (8.2 kΩ)
R325	7310000710	TRIMMER	RH0651C13J1YA (102)
R326	7030003420	S. RESISTOR	ERJ3GEYJ 681 V (680 Ω)
R327	7030004040	S. RESISTOR	ERJ3GEYJ 4R7 V (4.7 Ω)
R328	7030003570	S. RESISTOR	ERJ3GEYJ 123 V (12 kΩ)
R329	7030003400	S. RESISTOR	ERJ3GEYJ 471 V (470 Ω)
R330	7030003480	S. RESISTOR	ERJ3GEYJ 222 V (2.2 kΩ)
R331	7310002740	S. TRIMMER	RV-150 (RH03A3A14X0FC) 103
R332	7030003280	S. RESISTOR	ERJ3GEYJ 470 V (47 Ω)
R333	7030003560	S. RESISTOR	ERJ3GEYJ 103 V (10 kΩ)
R334	7030003800	S. RESISTOR	ERJ3GEYJ 105 V (1 MΩ)
R335	7030003560	S. RESISTOR	ERJ3GEYJ 103 V (10 kΩ)
R336	7310000820	TRIMMER	RH0651C16J0RA (105)
R337	7030003440	S. RESISTOR	ERJ3GEYJ 102 V (1 kΩ)
R338	7030003540	S. RESISTOR	ERJ3GEYJ 682 V (6.8 kΩ)
R339	7030003520	S. RESISTOR	ERJ3GEYJ 472 V (4.7 kΩ)
R341	7030003560	S. RESISTOR	ERJ3GEYJ 103 V (10 kΩ)
R342	7030003440	S. RESISTOR	ERJ3GEYJ 102 V (1 kΩ)
R343	7030003530	S. RESISTOR	ERJ3GEYJ 562 V (5.6 kΩ)
R344	7030003280	S. RESISTOR	ERJ3GEYJ 470 V (47 Ω)
R345	7030003590	S. RESISTOR	ERJ3GEYJ 183 V (18 kΩ)
R346	7030003600	S. RESISTOR	ERJ3GEYJ 223 V (22 kΩ)
R347	7010003910	RESISTOR	R20J 4.7 Ω
R348	7010003910	RESISTOR	R20J 4.7 Ω
R350	7030003280	S. RESISTOR	ERJ3GEYJ 470 V (47 Ω)
R351	7030003440	S. RESISTOR	ERJ3GEYJ 102 V (1 kΩ)
R352	7030003340	S. RESISTOR	ERJ3GEYJ 151 V (150 Ω)
R353	7030003320	S. RESISTOR	ERJ3GEYJ 101 V (100 Ω)
R354	7030003320	S. RESISTOR	ERJ3GEYJ 101 V (100 Ω)
R355	7030003320	S. RESISTOR	ERJ3GEYJ 101 V (100 Ω)
R358	7030003280	S. RESISTOR	ERJ3GEYJ 470 V (47 Ω)
R359	7010003830	RESISTOR	R20J 1 Ω

[MAIN UNIT]

REF. NO.	ORDER NO.	DESCRIPTION	
R360	7030003220	S. RESISTOR	ERJ3GEYJ 150 V (15 Ω)
R361	7030003220	S. RESISTOR	ERJ3GEYJ 150 V (15 Ω)
R362	7030003220	S. RESISTOR	ERJ3GEYJ 150 V (15 Ω)
R363	7030003220	S. RESISTOR	ERJ3GEYJ 150 V (15 Ω)
R364	7030003220	S. RESISTOR	ERJ3GEYJ 150 V (15 Ω)
R365	7030003220	S. RESISTOR	ERJ3GEYJ 150 V (15 Ω)
R366	7030003440	S. RESISTOR	ERJ3GEYJ 102 V (1 kΩ)
R367	7030003440	S. RESISTOR	ERJ3GEYJ 102 V (1 kΩ)
R368	7030003440	S. RESISTOR	ERJ3GEYJ 102 V (1 kΩ)
R369	7030003440	S. RESISTOR	ERJ3GEYJ 102 V (1 kΩ)
R370	7030003440	S. RESISTOR	ERJ3GEYJ 102 V (1 kΩ)
R371	7030003440	S. RESISTOR	ERJ3GEYJ 102 V (1 kΩ)
R372	7030005320	S. RESISTOR	RR0816P-103-D (10 kΩ)
R373	7030005330	S. RESISTOR	RR0816P-562-D (5.6 kΩ)
R374	7030005340	S. RESISTOR	RR0816P-332-D (3.3 kΩ)
R375	7030005350	S. RESISTOR	RR0816P-182-D (1.8 kΩ)
R376	7030005360	S. RESISTOR	RR0816P-751-D (750 Ω)
R377	7030003400	S. RESISTOR	ERJ3GEYJ 471 V (470 Ω)
R378	7030003520	S. RESISTOR	ERJ3GEYJ 472 V (4.7 kΩ)
R379	7030003640	S. RESISTOR	ERJ3GEYJ 473 V (47 kΩ)
R381	7030003400	S. RESISTOR	ERJ3GEYJ 471 V (470 Ω)
R383	7030003600	S. RESISTOR	ERJ3GEYJ 223 V (22 kΩ)
R384	7030003760	S. RESISTOR	ERJ3GEYJ 474 V (470 kΩ)
R385	7030003320	S. RESISTOR	ERJ3GEYJ 101 V (100 Ω)
R386	7030003650	S. RESISTOR	ERJ3GEYJ 563 V (56 kΩ)
R387	7030003650	S. RESISTOR	ERJ3GEYJ 563 V (56 kΩ)
R388	7030003650	S. RESISTOR	ERJ3GEYJ 563 V (56 kΩ)
R389	7030003520	S. RESISTOR	ERJ3GEYJ 472 V (4.7 kΩ)
R390	7030003680	S. RESISTOR	ERJ3GEYJ 104 V (100 kΩ)
R391	7030003760	S. RESISTOR	ERJ3GEYJ 474 V (470 kΩ)
R392	7030003600	S. RESISTOR	ERJ3GEYJ 223 V (22 kΩ)
R393	7030003560	S. RESISTOR	ERJ3GEYJ 103 V (10 kΩ)
R394	7030003560	S. RESISTOR	ERJ3GEYJ 103 V (10 kΩ)
R395	7030003480	S. RESISTOR	ERJ3GEYJ 222 V (2.2 kΩ)
R396	7030003640	S. RESISTOR	ERJ3GEYJ 473 V (47 kΩ)
R397	7030003640	S. RESISTOR	ERJ3GEYJ 473 V (47 kΩ)
R398	7030003640	S. RESISTOR	ERJ3GEYJ 473 V (47 kΩ)
R399	7030003640	S. RESISTOR	ERJ3GEYJ 473 V (47 kΩ)
R400	7030003440	S. RESISTOR	ERJ3GEYJ 102 V (1 kΩ)
R401	7030003330	S. RESISTOR	ERJ3GEYJ 121 V (120 Ω)
R402	7030003320	S. RESISTOR	ERJ3GEYJ 101 V (100 Ω)
R403	7030003520	S. RESISTOR	ERJ3GEYJ 472 V (4.7 kΩ)
R407	7310002580	S. TRIMMER	RV-108 (RH03A3A15X05A) 104
R408	7510000560	THERMISTOR	ERT-D2ZGL 801S
R409	7030003480	S. RESISTOR	ERJ3GEYJ 222 V (2.2 kΩ)
C1	4030006880	S. CERAMIC	C1608 JB 1H 472K-T-A
C2	4030008920	S. CERAMIC	C1608 JB 1C 473K-T-A
C3	4030006730	S. CERAMIC	C1608 SL 1H 680J-T-A
C4	4030006670	S. CERAMIC	C1608 SL 1H 270J-T-A
C5	4030006770	S. CERAMIC	C1608 SL 1H 151J-T-A
C6	4030006610	S. CERAMIC	C1608 SL 1H 100D-T-A
C7	4030006740	S. CERAMIC	C1608 SL 1H 820J-T-A
C8	4030008960	S. CERAMIC	C2012 JB 1C 104K-T-A
C9	4030006870	S. CERAMIC	C1608 JB 1H 222K-T-A
C10	4030008650	S. CERAMIC	C1608 JB 1H 332K-T-A
C11	4030008920	S. CERAMIC	C1608 JB 1C 473K-T-A
C12	4030006560	S. CERAMIC	C1608 SL 1H 050C-T-A
C13	4030008920	S. CERAMIC	C1608 JB 1C 473K-T-A
C14	4030006880	S. CERAMIC	C1608 JB 1H 472K-T-A
C15	4030006880	S. CERAMIC	C1608 JB 1H 472K-T-A
C16	4030006860	S. CERAMIC	C1608 JB 1H 102K-T-A
C17	4030006620	S. CERAMIC	C1608 SL 1H 120J-T-A
C18	4030006590	S. CERAMIC	C1608 SL 1H 080D-T-A
C19	4030006880	S. CERAMIC	C1608 JB 1H 472K-T-A
C20	4030006880	S. CERAMIC	C1608 JB 1H 472K-T-A
C21	4030006860	S. CERAMIC	C1608 JB 1H 102K-T-A
C22	4030006860	S. CERAMIC	C1608 JB 1H 102K-T-A
C23	4030006860	S. CERAMIC	C1608 JB 1H 102K-T-A
C24	4030006750	S. CERAMIC	C1608 SL 1H 101J-T-A
C25	4030006750	S. CERAMIC	C1608 SL 1H 101J-T-A
C26	4030006880	S. CERAMIC	C1608 JB 1H 472K-T-A
C27	4030006880	S. CERAMIC	C1608 JB 1H 472K-T-A

S.=Surface mount

[MAIN UNIT]

REF. NO.	ORDER NO.	DESCRIPTION
C28	4030006860	S. CERAMIC C1608 JB 1H 102K-T-A
C29	4030006880	S. CERAMIC C1608 JB 1H 472K-T-A
C30	4030006590	S. CERAMIC C1608 SL 1H 080D-T-A
C31	4030006590	S. CERAMIC C1608 SL 1H 080D-T-A
C32	4030006860	S. CERAMIC C1608 JB 1H 102K-T-A
C33	4030008960	S. CERAMIC C2012 JB 1C 104K-T-A
C34	4510003830	ELECTROLYTIC 50 MV R47 SW
C35	4510003860	ELECTROLYTIC 50 MV 3R3 SW
C36	4030006880	S. CERAMIC C1608 JB 1H 472K-T-A
C37	4030008960	S. CERAMIC C2012 JB 1C 104K-T-A
C38	4510003910	ELECTROLYTIC 16 MV 47 HW
C39	4030008960	S. CERAMIC C2012 JB 1C 104K-T-A
C40	4030008960	S. CERAMIC C2012 JB 1C 104K-T-A
C41	4030006880	S. CERAMIC C1608 JB 1H 472K-T-A
C42	4030008960	S. CERAMIC C2012 JB 1C 104K-T-A
C43	4030006880	S. CERAMIC C1608 JB 1H 472K-T-A
C44	4030006880	S. CERAMIC C1608 JB 1H 472K-T-A
C45	4030008960	S. CERAMIC C2012 JB 1C 104K-T-A
C46	4030008960	S. CERAMIC C2012 JB 1C 104K-T-A
C47	4030006880	S. CERAMIC C1608 JB 1H 472K-T-A
C48	4030006880	S. CERAMIC C1608 JB 1H 472K-T-A
C49	4030008960	S. CERAMIC C2012 JB 1C 104K-T-A
C50	4030008920	S. CERAMIC C1608 JB 1C 473K-T-A
C51	4030008920	S. CERAMIC C1608 JB 1C 473K-T-A
C52	4030006710	S. CERAMIC C1608 SL 1H 470J-T-A
C53	4030008960	S. CERAMIC C2012 JB 1C 104K-T-A
C54	4030008960	S. CERAMIC C2012 JB 1C 104K-T-A
C55	4030006880	S. CERAMIC C1608 JB 1H 472K-T-A
C56	4030008960	S. CERAMIC C2012 JB 1C 104K-T-A
C57	4030008960	S. CERAMIC C2012 JB 1C 104K-T-A
C59	4030008960	S. CERAMIC C2012 JB 1C 104K-T-A
C60	4030006830	S. CERAMIC C1608 SL 1H 331J-T-A
C61	4030006870	S. CERAMIC C1608 JB 1H 222K-T-A
C62	4030008960	S. CERAMIC C2012 JB 1C 104K-T-A
C63	4030006850	S. CERAMIC C1608 JB 1H 471K-T-A
C64	4030008960	S. CERAMIC C2012 JB 1C 104K-T-A
C65	4030006880	S. CERAMIC C1608 JB 1H 472K-T-A
C66	4030008960	S. CERAMIC C2012 JB 1C 104K-T-A
C67	4030008960	S. CERAMIC C2012 JB 1C 104K-T-A
C68	4030006860	S. CERAMIC C1608 JB 1H 102K-T-A
C69	4030008960	S. CERAMIC C2012 JB 1C 104K-T-A
C70	4030008960	S. CERAMIC C2012 JB 1C 104K-T-A
C71	4030008960	S. CERAMIC C2012 JB 1C 104K-T-A
C72	4030008960	S. CERAMIC C2012 JB 1C 104K-T-A
C73	4030008960	S. CERAMIC C2012 JB 1C 104K-T-A
C74	4030008960	S. CERAMIC C2012 JB 1C 104K-T-A
C75	4030006880	S. CERAMIC C1608 JB 1H 472K-T-A
C76	4030006860	S. CERAMIC C1608 JB 1H 102K-T-A
C77	4030006860	S. CERAMIC C1608 JB 1H 102K-T-A
C78	4030006880	S. CERAMIC C1608 JB 1H 472K-T-A
C79	4030006880	S. CERAMIC C1608 JB 1H 472K-T-A
C80	4030008920	S. CERAMIC C1608 JB 1C 473K-T-A
C81	4030008920	S. CERAMIC C1608 JB 1C 473K-T-A
C82	4030008920	S. CERAMIC C1608 JB 1C 473K-T-A
C83	4510005210	ELECTROLYTIC 50 MV 1 SWNP
C84	4030008470	S. CERAMIC C1608 JB 1H 272K-T-A
C85	4030006800	S. CERAMIC C1608 SL 1H 221J-T-A
C86	4030006870	S. CERAMIC C1608 JB 1H 222K-T-A
C87	4030008920	S. CERAMIC C1608 JB 1C 473K-T-A
C88	4030008920	S. CERAMIC C1608 JB 1C 473K-T-A
C89	4030009980	S. CERAMIC C1608 JB 1H 152K-T-A
C90	4030008470	S. CERAMIC C1608 JB 1H 272K-T-A
C91	4030008920	S. CERAMIC C1608 JB 1C 473K-T-A
C92	4030008920	S. CERAMIC C1608 JB 1C 473K-T-A
C93	4030009970	S. CERAMIC C1608 JB 1H 182K-T-A
C94	4030006810	S. CERAMIC C1608 SL 1H 271J-T-A
C95	4030006860	S. CERAMIC C1608 JB 1H 102K-T-A
C96	4030008850	S. CERAMIC C1608 JB 1C 123K-T-A
C97	4030008470	S. CERAMIC C1608 JB 1H 272K-T-A
C98	4030009980	S. CERAMIC C1608 JB 1H 152K-T-A
C99	4030008920	S. CERAMIC C1608 JB 1C 473K-T-A
C100	4030008920	S. CERAMIC C1608 JB 1C 473K-T-A
C101	4030010020	S. CERAMIC C1608 JB 1H 122K-T-A
C102	4030006750	S. CERAMIC C1608 SL 1H 101J-T-A
C103	4030010020	S. CERAMIC C1608 JB 1H 122K-T-A

[MAIN UNIT]

REF. NO.	ORDER NO.	DESCRIPTION
C104	4030008920	S. CERAMIC C1608 JB 1C 473K-T-A
C105	4030006850	S. CERAMIC C1608 JB 1H 471K-T-A
C106	4030006730	S. CERAMIC C1608 SL 1H 680J-T-A
C107	4030006810	S. CERAMIC C1608 SL 1H 271J-T-A
C108	4030010020	S. CERAMIC C1608 JB 1H 122K-T-A
C109	4030010040	S. CERAMIC C1608 JB 1H 561K-T-A
C110	4030008770	S. CERAMIC C1608 JB 1H 562K-T-A
C111	4030008920	S. CERAMIC C1608 JB 1C 473K-T-A
C112	4030008920	S. CERAMIC C1608 JB 1C 473K-T-A
C113	4030006830	S. CERAMIC C1608 SL 1H 331J-T-A
C114	4030006720	S. CERAMIC C1608 SL 1H 560J-T-A
C115	4030006830	S. CERAMIC C1608 SL 1H 331J-T-A
C116	4030009580	S. CERAMIC C1608 JB 1H 681K-T-A
C117	4030006830	S. CERAMIC C1608 SL 1H 331J-T-A
C118	4030008470	S. CERAMIC C1608 JB 1H 272K-T-A
C119	4030008920	S. CERAMIC C1608 JB 1C 473K-T-A
C120	4030008920	S. CERAMIC C1608 JB 1C 473K-T-A
C121	4030006810	S. CERAMIC C1608 SL 1H 271J-T-A
C122	4030006720	S. CERAMIC C1608 SL 1H 560J-T-A
C123	4030006770	S. CERAMIC C1608 SL 1H 151J-T-A
C124	4030006850	S. CERAMIC C1608 JB 1H 471K-T-A
C125	4030006800	S. CERAMIC C1608 SL 1H 221J-T-A
C126	4030009980	S. CERAMIC C1608 JB 1H 152K-T-A
C127	4030008920	S. CERAMIC C1608 JB 1C 473K-T-A
C128	4030008920	S. CERAMIC C1608 JB 1C 473K-T-A
C129	4030006800	S. CERAMIC C1608 SL 1H 221J-T-A
C130	4030006690	S. CERAMIC C1608 SL 1H 330J-T-A
C131	4030006760	S. CERAMIC C1608 SL 1H 121J-T-A
C132	4030006810	S. CERAMIC C1608 SL 1H 271J-T-A
C133	4030006770	S. CERAMIC C1608 SL 1H 151J-T-A
C134	4030010020	S. CERAMIC C1608 JB 1H 122K-T-A
C135	4030008920	S. CERAMIC C1608 JB 1C 473K-T-A
C136	4030008920	S. CERAMIC C1608 JB 1C 473K-T-A
C137	4030006690	S. CERAMIC C1608 SL 1H 330J-T-A
C138	4030006760	S. CERAMIC C1608 SL 1H 121J-T-A
C139	4030006700	S. CERAMIC C1608 SL 1H 390J-T-A
C140	4030006730	S. CERAMIC C1608 SL 1H 680J-T-A
C141	4030006800	S. CERAMIC C1608 SL 1H 221J-T-A
C142	4030006750	S. CERAMIC C1608 SL 1H 101J-T-A
C143	4030009490	S. CERAMIC C1608 JB 1H 821K-T-A
C144	4030008920	S. CERAMIC C1608 JB 1C 473K-T-A
C145	4030008920	S. CERAMIC C1608 JB 1C 473K-T-A
C146	4030006750	S. CERAMIC C1608 SL 1H 101J-T-A
C147	4030008920	S. CERAMIC C1608 JB 1C 473K-T-A
C148	4030008920	S. CERAMIC C1608 JB 1C 473K-T-A
C149	4030008920	S. CERAMIC C1608 JB 1C 473K-T-A
C150	4030008920	S. CERAMIC C1608 JB 1C 473K-T-A
C151	4030008960	S. CERAMIC C2012 JB 1C 104K-T-A
C152	4030006770	S. CERAMIC C1608 SL 1H 151J-T-A
C153	4030006610	S. CERAMIC C1608 SL 1H 100D-T-A
C154	4030006740	S. CERAMIC C1608 SL 1H 820J-T-A
C155	4030006610	S. CERAMIC C1608 SL 1H 100D-T-A
C156	4030008960	S. CERAMIC C2012 JB 1C 104K-T-A
C157	4030008960	S. CERAMIC C2012 JB 1C 104K-T-A
C158	4030006860	S. CERAMIC C1608 JB 1H 102K-T-A
C159	4030006880	S. CERAMIC C1608 JB 1H 472K-T-A
C160	4030006560	S. CERAMIC C1608 SL 1H 050C-T-A
C161	4030008920	S. CERAMIC C1608 JB 1C 473K-T-A
C162	4030006860	S. CERAMIC C1608 JB 1H 102K-T-A
C163	4030006590	S. CERAMIC C1608 SL 1H 080D-T-A
C164	4030006590	S. CERAMIC C1608 SL 1H 080D-T-A
C165	4030006880	S. CERAMIC C1608 JB 1H 472K-T-A
C167	4030008920	S. CERAMIC C1608 JB 1C 473K-T-A
C168	4030006880	S. CERAMIC C1608 JB 1H 472K-T-A
C169	4030006560	S. CERAMIC C1608 SL 1H 050C-T-A
C170	4030006880	S. CERAMIC C1608 JB 1H 472K-T-A
C171	4510003790	ELECTROLYTIC 16 MV 10 SW
C172	4030006860	S. CERAMIC C1608 JB 1H 102K-T-A
C174	4510003800	ELECTROLYTIC 25 MV 4R7 SW
C175	4510003830	ELECTROLYTIC 50 MV R47 SW
C177	4030006880	S. CERAMIC C1608 JB 1H 472K-T-A
C178	4510003910	ELECTROLYTIC 16 MV 47 HW
C179	4030006750	S. CERAMIC C1608 SL 1H 101J-T-A
C180	4030006770	S. CERAMIC C1608 SL 1H 151J-T-A
C181	4030008920	S. CERAMIC C1608 JB 1C 473K-T-A

S.=Surface mount

[MAIN UNIT]

REF. NO.	ORDER NO.	DESCRIPTION
C182	4510003830	ELECTROLYTIC 50 MV R47 SW
C183	4030006880	S. CERAMIC C1608 JB 1H 472K-T-A
C184	4030008920	S. CERAMIC C1608 JB 1C 473K-T-A
C185	4510003910	ELECTROLYTIC 16 MV 47 HW
C186	4030008920	S. CERAMIC C1608 JB 1C 473K-T-A
C187	4510003830	ELECTROLYTIC 50 MV R47 SW
C188	4310000440	MYLAR 50 F2D 473J
C190	4030006880	S. CERAMIC C1608 JB 1H 472K-T-A
C191	4510003830	ELECTROLYTIC 50 MV R47 SW
C192	4030008920	S. CERAMIC C1608 JB 1C 473K-T-A
C193	4030008960	S. CERAMIC C2012 JB 1C 104K-T-A
C194	4510003790	ELECTROLYTIC 16 MV 10 SW
C195	4030008920	S. CERAMIC C1608 JB 1C 473K-T-A
C196	4030006760	S. CERAMIC C1608 SL 1H 121J-T-A
C197	4030006860	S. CERAMIC C1608 JB 1H 102K-T-A
C198	4030006880	S. CERAMIC C1608 JB 1H 472K-T-A
C199	4030008920	S. CERAMIC C1608 JB 1C 473K-T-A
C200	4510004600	ELECTROLYTIC 16 MV 1000 HC
C201	4510004590	ELECTROLYTIC 16 MV 470 HC
C202	4510004990	ELECTROLYTIC 16 MV 100 HC
C203	4510004990	ELECTROLYTIC 16 MV 100 HC
C204	4510005000	ELECTROLYTIC 16 MV 220 HC
C205	4030008920	S. CERAMIC C1608 JB 1C 473K-T-A
C206	4510004990	ELECTROLYTIC 16 MV 100 HC
C207	4510003820	ELECTROLYTIC 50 MV R22 SW
C208	4030006870	S. CERAMIC C1608 JB 1H 222K-T-A
C209	4310000400	MYLAR 50 F2D 223J
C210	4510003820	ELECTROLYTIC 50 MV R22 SW
C211	4510003790	ELECTROLYTIC 16 MV 10 SW
C212	4510003910	ELECTROLYTIC 16 MV 47 HW
C213	4030008960	S. CERAMIC C2012 JB 1C 104K-T-A
C214	4030008920	S. CERAMIC C1608 JB 1C 473K-T-A
C215	4030008960	S. CERAMIC C2012 JB 1C 104K-T-A
C216	4030006800	S. CERAMIC C1608 SL 1H 221J-T-A
C218	4030008960	S. CERAMIC C2012 JB 1C 104K-T-A
C219	4030008920	S. CERAMIC C1608 JB 1C 473K-T-A
C221	4030008960	S. CERAMIC C2012 JB 1C 104K-T-A
C222	4030008960	S. CERAMIC C2012 JB 1C 104K-T-A
C223	4030008960	S. CERAMIC C2012 JB 1C 104K-T-A
C224	4030006880	S. CERAMIC C1608 JB 1H 472K-T-A
C225	4030008920	S. CERAMIC C1608 JB 1C 473K-T-A
C227	4030006880	S. CERAMIC C1608 JB 1H 472K-T-A
C228	4030008920	S. CERAMIC C1608 JB 1C 473K-T-A
C229	4510005210	ELECTROLYTIC 50 MV 1 SWNP
C230	4030006660	S. CERAMIC C1608 SL 1H 220J-T-A
C231	4030006880	S. CERAMIC C1608 JB 1H 472K-T-A
C232	4030008920	S. CERAMIC C1608 JB 1C 473K-T-A
C233	4510003790	ELECTROLYTIC 16 MV 10 SW
C234	4030008960	S. CERAMIC C2012 JB 1C 104K-T-A
C235	4030008920	S. CERAMIC C1608 JB 1C 473K-T-A
C236	4030008920	S. CERAMIC C1608 JB 1C 473K-T-A
C237	4030008960	S. CERAMIC C2012 JB 1C 104K-T-A
C239	4030008960	S. CERAMIC C2012 JB 1C 104K-T-A
C240	4510004600	ELECTROLYTIC 16 MV 1000 HC
C241	4030008920	S. CERAMIC C1608 JB 1C 473K-T-A
C242	4510003790	ELECTROLYTIC 16 MV 10 SW
C243	4030008920	S. CERAMIC C1608 JB 1C 473K-T-A
C244	4510003790	ELECTROLYTIC 16 MV 10 SW
C246	4030006860	S. CERAMIC C1608 JB 1H 102K-T-A
C247	4510003790	ELECTROLYTIC 16 MV 10 SW
C248	4510003840	ELECTROLYTIC 50 MV 1 SW
C249	4510003850	ELECTROLYTIC 50 MV 2R2 SW
C250	4030008920	S. CERAMIC C1608 JB 1C 473K-T-A
C251	4030006750	S. CERAMIC C1608 SL 1H 101J-T-A
C252	4030006850	S. CERAMIC C1608 JB 1H 471K-T-A
C253	4030006750	S. CERAMIC C1608 SL 1H 101J-T-A
C254	4510003790	ELECTROLYTIC 16 MV 10 SW
C255	4030008920	S. CERAMIC C1608 JB 1C 473K-T-A
C256	4510003820	ELECTROLYTIC 50 MV R22 SW
C257	4030008920	S. CERAMIC C1608 JB 1C 473K-T-A
C258	4030006860	S. CERAMIC C1608 JB 1H 102K-T-A
C259	4030006880	S. CERAMIC C1608 JB 1H 472K-T-A
C260	4030006880	S. CERAMIC C1608 JB 1H 472K-T-A
C261	4510004140	ELECTROLYTIC 50 MV 10 HW
C262	4030008920	S. CERAMIC C1608 JB 1C 473K-T-A

[MAIN UNIT]

REF. NO.	ORDER NO.	DESCRIPTION
C263	4030008920	S. CERAMIC C1608 JB 1C 473K-T-A
C264	4510003790	ELECTROLYTIC 16 MV 10 SW
C265	4510003790	ELECTROLYTIC 16 MV 10 SW
C266	4510003790	ELECTROLYTIC 16 MV 10 SW
C267	4510003800	ELECTROLYTIC 25 MV 4R7 SW
C268	4510003840	ELECTROLYTIC 50 MV 1 SW
C269	4030008920	S. CERAMIC C1608 JB 1C 473K-T-A
C270	4510005240	ELECTROLYTIC 16 MV 22 SWB
C271	4510003840	ELECTROLYTIC 50 MV 1 SW
C272	4030008920	S. CERAMIC C1608 JB 1C 473K-T-A
C273	4030006900	S. CERAMIC C1608 JB 1E 103K-T-A
C274	4550003130	S. TANTALUM TEMSVB2 1C 475M-8L
C275	4030006900	S. CERAMIC C1608 JB 1E 103K-T-A
C276	4550003250	S. TANTALUM TEMSVA 1V 474M-8L
C277	4030006880	S. CERAMIC C1608 JB 1H 472K-T-A
C278	4310000400	MYLAR 50 F2D 223J
C279	4310000400	MYLAR 50 F2D 223J
C280	4310000400	MYLAR 50 F2D 223J
C281	4510003910	ELECTROLYTIC 16 MV 47 HW
C282	4030008920	S. CERAMIC C1608 JB 1C 473K-T-A
C283	4030006880	S. CERAMIC C1608 JB 1H 472K-T-A
C284	4550002120	TANTALUM DN 1C 220M
C285	4510003840	ELECTROLYTIC 50 MV 1 SW
C286	4510003850	ELECTROLYTIC 50 MV 2R2 SW
C287	4510003840	ELECTROLYTIC 50 MV 1 SW
C288	4030006880	S. CERAMIC C1608 JB 1H 472K-T-A
C289	4030006880	S. CERAMIC C1608 JB 1H 472K-T-A
C290	4510003840	ELECTROLYTIC 50 MV 1 SW
C292	4030008920	S. CERAMIC C1608 JB 1C 473K-T-A
C293	4510003910	ELECTROLYTIC 16 MV 47 HW
C294	4030008920	S. CERAMIC C1608 JB 1C 473K-T-A
C295	4030008920	S. CERAMIC C1608 JB 1C 473K-T-A
C296	4030008920	S. CERAMIC C1608 JB 1C 473K-T-A
C297	4030008920	S. CERAMIC C1608 JB 1C 473K-T-A
C298	4030008920	S. CERAMIC C1608 JB 1C 473K-T-A
C299	4030008920	S. CERAMIC C1608 JB 1C 473K-T-A
C300	4030008920	S. CERAMIC C1608 JB 1C 473K-T-A
C301	4510004590	ELECTROLYTIC 16 MV 470 HC
C302	4030006880	S. CERAMIC C1608 JB 1H 472K-T-A
C303	4030006880	S. CERAMIC C1608 JB 1H 472K-T-A
C304	4030006880	S. CERAMIC C1608 JB 1H 472K-T-A
C305	4030006880	S. CERAMIC C1608 JB 1H 472K-T-A
C306	4030006880	S. CERAMIC C1608 JB 1H 472K-T-A
C307	4030006880	S. CERAMIC C1608 JB 1H 472K-T-A
C308	4030006880	S. CERAMIC C1608 JB 1H 472K-T-A
C310	4030006860	S. CERAMIC C1608 JB 1H 102K-T-A
C311	4030006880	S. CERAMIC C1608 JB 1H 472K-T-A
C312	4030006880	S. CERAMIC C1608 JB 1H 472K-T-A
C324	4030006860	S. CERAMIC C1608 JB 1H 102K-T-A
C346	4030008920	S. CERAMIC C1608 JB 1C 473K-T-A
C347	4550000400	TANTALUM DN 1C 2R2M
C348	4030008960	S. CERAMIC C2012 JB 1C 104K-T-A
C349	4030008920	S. CERAMIC C1608 JB 1C 473K-T-A
C350	4030006880	S. CERAMIC C1608 JB 1H 472K-T-A
C355	4030006880	S. CERAMIC C1608 JB 1H 472K-T-A
C359	4030008920	S. CERAMIC C1608 JB 1C 473K-T-A
C361	4030006880	S. CERAMIC C1608 JB 1H 472K-T-A
C362	4030006880	S. CERAMIC C1608 JB 1H 472K-T-A
C363	4030006880	S. CERAMIC C1608 JB 1H 472K-T-A
C364	4030006880	S. CERAMIC C1608 JB 1H 472K-T-A
C365	4030006880	S. CERAMIC C1608 JB 1H 472K-T-A
C366	4030006880	S. CERAMIC C1608 JB 1H 472K-T-A
C367	4030006900	S. CERAMIC C1608 JB 1E 103K-T-A
C368	4030008960	S. CERAMIC C2012 JB 1C 104K-T-A
C370	4030006850	S. CERAMIC C1608 JB 1H 471K-T-A
C371	4030010020	S. CERAMIC C1608 JB 1H 122K-T-A
C372	4030006870	S. CERAMIC C1608 JB 1H 222K-T-A
C373	4030006840	S. CERAMIC C1608 SL 1H 391J-T-A
C374	4510003840	ELECTROLYTIC 50 MV 1 SW
C375	4030006880	S. CERAMIC C1608 JB 1H 472K-T-A
C376	4030006880	S. CERAMIC C1608 JB 1H 472K-T-A
C377	4030006880	S. CERAMIC C1608 JB 1H 472K-T-A
C378	4030006880	S. CERAMIC C1608 JB 1H 472K-T-A
C379	4030006880	S. CERAMIC C1608 JB 1H 472K-T-A
C380	4030006880	S. CERAMIC C1608 JB 1H 472K-T-A

S.=Surface mount

[MAIN UNIT]

REF. NO.	ORDER NO.	DESCRIPTION	
C381	4030006880	S. CERAMIC	C1608 JB 1H 472K-T-A
C382	4030006860	S. CERAMIC	C1608 JB 1H 102K-T-A
C383	4030006850	S. CERAMIC	C1608 JB 1H 471K-T-A
C384	4030006880	S. CERAMIC	C1608 JB 1H 472K-T-A
C385	4030006880	S. CERAMIC	C1608 JB 1H 472K-T-A
C386	4030006880	S. CERAMIC	C1608 JB 1H 472K-T-A
C387	4610001260	S. TRIMMER	ECR-JA020 E12W
C388	4030006860	S. CERAMIC	C1608 JB 1H 102K-T-A
C389	4030006880	S. CERAMIC	C1608 JB 1H 472K-T-A
C390	4030006740	S. CERAMIC	C1608 SL 1H 820J-T-A
C391	4030006740	S. CERAMIC	C1608 SL 1H 820J-T-A
RL1	6330000180	RELAY	MZ-12HG
RL2	6330000560	RELAY	OUC-SH-114D
J1	6510003250	CONNECTOR	TMP-J01X-A2
J2	6510003250	CONNECTOR	TMP-J01X-A2
J3	6510003250	CONNECTOR	TMP-J01X-A2
J4	6510003460	CONNECTOR	B10B-EH-S
J5	6510003400	CONNECTOR	B04B-EH-S
J6	6450001440	CONNECTOR	HSJ1403-01-010 [CLONING]
J7	6510003410	CONNECTOR	B05B-EH-S
J8	6510003410	CONNECTOR	B05B-EH-S
J9	6510016030	CONNECTOR	52089-1620
J10	6510016030	CONNECTOR	52089-1620
J11	6510003400	CONNECTOR	B04B-EH-S
J12	6510003420	CONNECTOR	B06B-EH-S
J13	6450001130	CONNECTOR	JPJ2042-01-110 [SEND/ALC]
J14	6510003390	CONNECTOR	B03B-EH-S
J15	6510003400	CONNECTOR	B04B-EH-S
J16	6510003390	CONNECTOR	B03B-EH-S
J17	6450000170	CONNECTOR	TCS4480-01-1111 [ACC (1)]
J18	6450000160	CONNECTOR	TCS4470-01-1111 [ACC (2)]
J19	6450001440	CONNECTOR	HSJ1403-01-010 [EXT SP]
J20	6450001260	CONNECTOR	HLJ4306-01-3080 [KEY]
J21	6510003250	CONNECTOR	TMP-J01X-A2
J22	6510004890	CONNECTOR	3022-09A
J23	6510000780	CONNECTOR	3022-06A
J24	6510003390	CONNECTOR	B03B-EH-S
EP1	0910039514	PCB	B 3857D (MAIN)
EP2	6910000310	INSULATION PLATE	B312D INSULATION BUSH
EP3	6910000340	SHEET	P101 KD (Insulating sheet)

[PLL UNIT]

REF. NO.	ORDER NO.	DESCRIPTION	
Q19	1560000330	S. FET	2SK210-GR (TE85R)
Q20	1560000330	S. FET	2SK210-GR (TE85R)
Q21	1560000330	S. FET	2SK210-GR (TE85R)
Q22	1530002060	S. TRANSISTOR	2SC4081 T107 R
Q23	1530002060	S. TRANSISTOR	2SC4081 T107 R
Q24	1530002060	S. TRANSISTOR	2SC4081 T107 R
Q25	1530002060	S. TRANSISTOR	2SC4081 T107 R
Q26	1530002370	S. TRANSISTOR	2SC2714-O (TE85R)
Q27	1530002370	S. TRANSISTOR	2SC2714-O (TE85R)
Q28	1530002370	S. TRANSISTOR	2SC2714-O (TE85R)
Q29	1530002370	S. TRANSISTOR	2SC2714-O (TE85R)
Q30	1530002370	S. TRANSISTOR	2SC2714-O (TE85R)
Q32	1530002370	S. TRANSISTOR	2SC2714-O (TE85R)
D2	1750000020	S. DIODE	1SS184 (TE85R)
D3	1720000230	VARICAP	1SV101
D4	1720000230	VARICAP	1SV101
D5	1720000230	VARICAP	1SV101
D6	1720000230	VARICAP	1SV101
D7	1720000230	VARICAP	1SV101
D8	1750000020	S. DIODE	1SS184 (TE85R)
D9	1750000020	S. DIODE	1SS184 (TE85R)
D10	1750000020	S. DIODE	1SS184 (TE85R)
D11	1750000020	S. DIODE	1SS184 (TE85R)
D12	1750000020	S. DIODE	1SS184 (TE85R)
D13	1730000510	S. ZENER	RD3.9M-T2B2
D14	1750000020	S. DIODE	1SS184 (TE85R)
D15	1750000070	S. DIODE	1SS226 (TE85R)
D16	1750000070	S. DIODE	1SS226 (TE85R)
D17	1750000070	S. DIODE	1SS226 (TE85R)
X1	6050007350	XTAL	CR-337 (#02)
	6050008870	XTAL	CR-338 (#01)
L1	6200001830	S. COIL	NL 322522T-100J
L2	6200001830	S. COIL	NL 322522T-100J
L3	6170000180	COIL	LW-19
L4	6150000760	COIL	LS-94
L5	6200001830	S. COIL	NL 322522T-100J
L6	6150000990	COIL	LS-114
L7	6150000990	COIL	LS-114
L8	6200001830	S. COIL	NL 322522T-100J
L9	6200001830	S. COIL	NL 322522T-100J
L10	6180000880	COIL	LAL 03NA 100K
L11	6190000990	COIL	C-14207-8.5
L12	6200002960	S. COIL	NL 322522T-4R7J-3
L13	6200003320	S. COIL	NL 322522T-3R3J-3
L14	6200003140	S. COIL	NL 322522T-150J
L15	6200003140	S. COIL	NL 322522T-150J
L18	6140002220	COIL	LR-270
L19	6190000950	COIL	C-13975-6.5T
L20	6140002220	COIL	LR-270
L21	6190000950	COIL	C-13975-6.5T
L22	6140002220	COIL	LR-270
L23	6190000950	COIL	C-13975-6.5T
L24	6140002220	COIL	LR-270
L25	6190000950	COIL	C-13975-6.5T
L26	6200003260	S. COIL	NL 322522T-101J
L27	6200000400	S. COIL	MLF3216D R68M-T
L28	6200000400	S. COIL	MLF3216D R68M-T
L29	6200000400	S. COIL	MLF3216D R68M-T
L30	6200000400	S. COIL	MLF3216D R68M-T
L31	6200003260	S. COIL	NL 322522T-101J
L33	6200003050	S. COIL	NL 322522T-R82J-3
L34	6200003430	S. COIL	NL 322522T-R10J
L35	6200003420	S. COIL	NL 322522T-R15J-3
L36	6200003430	S. COIL	NL 322522T-R10J
L37	6200003450	S. COIL	NL 322522T-082J
L39	6200003050	S. COIL	NL 322522T-R82J-3
L40	6200003320	S. COIL	NL 322522T-3R3J-3
L41	6200001830	S. COIL	NL 322522T-100J
L42	6200003050	S. COIL	NL 322522T-R82J-3

[PLL UNIT]

REF. NO.	ORDER NO.	DESCRIPTION	
IC1	1180001070	S. IC	TA7805F (TE16L)
IC2	1130005741	S. IC	TC74AC74F (TP1)
IC3	1130006520	S. IC	CXD1225M-1
IC4	1130006670	S. IC	TC74AC390F
IC5	1110001900	S. IC	μPC4570G2-T1
IC6	1140003640	S. IC	SC-1246 (L7B1106)
IC7	1130003610	S. IC	TC4SU69F (TE85R)
Q9	1530002370	S. TRANSISTOR	2SC2714-O (TE85R)
Q10	1530002370	S. TRANSISTOR	2SC2714-O (TE85R)
Q11	1530002600	S. TRANSISTOR	2SC4215-O (TE85R)
Q12	1590000680	S. TRANSISTOR	DTC114EU T107
Q13	1560000530	S. FET	2SK880-GR (TE85R)
Q14	1530002050	S. TRANSISTOR	2SC3661-TA
Q15	1560000330	S. FET	2SK210-GR (TE85R)
Q16	1560000560	S. FET	2SK882-GR (TE85L)
Q18	1560000330	S. FET	2SK210-GR (TE85R)

S.=Surface mount

[PLL UNIT]

REF. NO.	ORDER NO.	DESCRIPTION	
L43	6200003320	S. COIL	NL 322522T-3R3J-3
L44	6200003160	S. COIL	NL 322522T-270J
L45	6200001710	S. COIL	NL 322522T-220J
L46	6200003150	S. COIL	NL 322522T-180J
R1	7030003320	S. RESISTOR	ERJ3GEYJ 101 V (100 Ω)
R2	7030003390	S. RESISTOR	ERJ3GEYJ 391 V (390 Ω)
R3	7030003550	S. RESISTOR	ERJ3GEYJ 822 V (8.2 kΩ)
R4	7030003550	S. RESISTOR	ERJ3GEYJ 822 V (8.2 kΩ)
R5	7030003390	S. RESISTOR	ERJ3GEYJ 391 V (390 Ω)
R6	7030003320	S. RESISTOR	ERJ3GEYJ 101 V (100 Ω)
R7	7030003360	S. RESISTOR	ERJ3GEYJ 221 V (220 Ω)
R8	7030003360	S. RESISTOR	ERJ3GEYJ 221 V (220 Ω)
R9	7030003600	S. RESISTOR	ERJ3GEYJ 223 V (22 kΩ)
R10	7030003600	S. RESISTOR	ERJ3GEYJ 223 V (22 kΩ)
R12	7030003580	S. RESISTOR	ERJ3GEYJ 153 V (15 kΩ)
R13	7030003400	S. RESISTOR	ERJ3GEYJ 471 V (470 Ω)
R14	7030003520	S. RESISTOR	ERJ3GEYJ 472 V (4.7 kΩ)
R15	7030003320	S. RESISTOR	ERJ3GEYJ 101 V (100 Ω)
R16	7030003600	S. RESISTOR	ERJ3GEYJ 223 V (22 kΩ)
R17	7030003360	S. RESISTOR	ERJ3GEYJ 221 V (220 Ω)
R18	7030003360	S. RESISTOR	ERJ3GEYJ 221 V (220 Ω)
R19	7030003360	S. RESISTOR	ERJ3GEYJ 221 V (220 Ω)
R20	7030003400	S. RESISTOR	ERJ3GEYJ 471 V (470 Ω)
R21	7030003560	S. RESISTOR	ERJ3GEYJ 103 V (10 kΩ)
R22	7030003320	S. RESISTOR	ERJ3GEYJ 101 V (100 Ω)
R23	7030003560	S. RESISTOR	ERJ3GEYJ 103 V (10 kΩ)
R24	7030003460	S. RESISTOR	ERJ3GEYJ 152 V (1.5 kΩ)
R26	7030003320	S. RESISTOR	ERJ3GEYJ 101 V (100 Ω)
R27	7030003320	S. RESISTOR	ERJ3GEYJ 101 V (100 Ω)
R28	7030003440	S. RESISTOR	ERJ3GEYJ 102 V (1 kΩ)
R29	7030003560	S. RESISTOR	ERJ3GEYJ 103 V (10 kΩ)
R30	7030003440	S. RESISTOR	ERJ3GEYJ 102 V (1 kΩ)
R31	7030003400	S. RESISTOR	ERJ3GEYJ 471 V (470 Ω)
R32	7030003440	S. RESISTOR	ERJ3GEYJ 102 V (1 kΩ)
R33	7030003320	S. RESISTOR	ERJ3GEYJ 101 V (100 Ω)
R34	7030003700	S. RESISTOR	ERJ3GEYJ 154 V (150 kΩ)
R35	7030003680	S. RESISTOR	ERJ3GEYJ 104 V (100 kΩ)
R36	7030003320	S. RESISTOR	ERJ3GEYJ 101 V (100 Ω)
R37	7030003340	S. RESISTOR	ERJ3GEYJ 151 V (150 Ω)
R38	7030003320	S. RESISTOR	ERJ3GEYJ 101 V (100 Ω)
R39	7030003560	S. RESISTOR	ERJ3GEYJ 103 V (10 kΩ)
R40	7030003400	S. RESISTOR	ERJ3GEYJ 471 V (470 Ω)
R41	7030003640	S. RESISTOR	ERJ3GEYJ 473 V (47 kΩ)
R42	7030003560	S. RESISTOR	ERJ3GEYJ 103 V (10 kΩ)
R43	7030003510	S. RESISTOR	ERJ3GEYJ 392 V (3.9 kΩ)
R44	7030003640	S. RESISTOR	ERJ3GEYJ 473 V (47 kΩ)
R46	7030003280	S. RESISTOR	ERJ3GEYJ 470 V (47 Ω)
R49	7030003680	S. RESISTOR	ERJ3GEYJ 104 V (100 kΩ)
R50	7030003680	S. RESISTOR	ERJ3GEYJ 104 V (100 kΩ)
R51	7030003680	S. RESISTOR	ERJ3GEYJ 104 V (100 kΩ)
R52	7030003680	S. RESISTOR	ERJ3GEYJ 104 V (100 kΩ)
R53	7030003680	S. RESISTOR	ERJ3GEYJ 104 V (100 kΩ)
R54	7030003680	S. RESISTOR	ERJ3GEYJ 104 V (100 kΩ)
R55	7030003680	S. RESISTOR	ERJ3GEYJ 104 V (100 kΩ)
R56	7030003680	S. RESISTOR	ERJ3GEYJ 104 V (100 kΩ)
R57	7030003350	S. RESISTOR	ERJ3GEYJ 181 V (180 Ω)
R58	7030003340	S. RESISTOR	ERJ3GEYJ 151 V (150 Ω)
R60	7030003500	S. RESISTOR	ERJ3GEYJ 332 V (3.3 kΩ)
R61	7030003640	S. RESISTOR	ERJ3GEYJ 473 V (47 kΩ)
R62	7030003560	S. RESISTOR	ERJ3GEYJ 103 V (10 kΩ)
R63	7030003340	S. RESISTOR	ERJ3GEYJ 151 V (150 Ω)
R64	7030003500	S. RESISTOR	ERJ3GEYJ 332 V (3.3 kΩ)
R65	7030003640	S. RESISTOR	ERJ3GEYJ 473 V (47 kΩ)
R66	7030003560	S. RESISTOR	ERJ3GEYJ 103 V (10 kΩ)
R67	7030003280	S. RESISTOR	ERJ3GEYJ 470 V (47 Ω)
R68	7030003340	S. RESISTOR	ERJ3GEYJ 151 V (150 Ω)
R69	7030003500	S. RESISTOR	ERJ3GEYJ 332 V (3.3 kΩ)
R70	7030003640	S. RESISTOR	ERJ3GEYJ 473 V (47 kΩ)
R71	7030003560	S. RESISTOR	ERJ3GEYJ 103 V (10 kΩ)
R72	7030003340	S. RESISTOR	ERJ3GEYJ 151 V (150 Ω)
R73	7030003500	S. RESISTOR	ERJ3GEYJ 332 V (3.3 kΩ)
R74	7030003640	S. RESISTOR	ERJ3GEYJ 473 V (47 kΩ)
R75	7030003560	S. RESISTOR	ERJ3GEYJ 103 V (10 kΩ)

[PLL UNIT]

REF. NO.	ORDER NO.	DESCRIPTION	
R76	7030003360	S. RESISTOR	ERJ3GEYJ 221 V (220 Ω)
R77	7030003520	S. RESISTOR	ERJ3GEYJ 472 V (4.7 kΩ)
R78	7030003380	S. RESISTOR	ERJ3GEYJ 331 V (330 Ω)
R79	7030003360	S. RESISTOR	ERJ3GEYJ 221 V (220 Ω)
R80	7030003600	S. RESISTOR	ERJ3GEYJ 223 V (22 kΩ)
R81	7030003600	S. RESISTOR	ERJ3GEYJ 223 V (22 kΩ)
R82	7030003320	S. RESISTOR	ERJ3GEYJ 101 V (100 Ω)
R83	7030003400	S. RESISTOR	ERJ3GEYJ 471 V (470 Ω)
R84	7030003560	S. RESISTOR	ERJ3GEYJ 103 V (10 kΩ)
R85	7030003560	S. RESISTOR	ERJ3GEYJ 103 V (10 kΩ)
R86	7030003320	S. RESISTOR	ERJ3GEYJ 101 V (100 Ω)
R87	7030003360	S. RESISTOR	ERJ3GEYJ 221 V (220 Ω)
R88	7030003320	S. RESISTOR	ERJ3GEYJ 101 V (100 Ω)
R89	7030003400	S. RESISTOR	ERJ3GEYJ 471 V (470 Ω)
R90	7030003400	S. RESISTOR	ERJ3GEYJ 471 V (470 Ω)
R91	7030003440	S. RESISTOR	ERJ3GEYJ 102 V (1 kΩ)
R92	7030003440	S. RESISTOR	ERJ3GEYJ 102 V (1 kΩ)
R93	7030003440	S. RESISTOR	ERJ3GEYJ 102 V (1 kΩ)
R94	7030003440	S. RESISTOR	ERJ3GEYJ 102 V (1 kΩ)
R95	7030003440	S. RESISTOR	ERJ3GEYJ 102 V (1 kΩ)
R96	7030003440	S. RESISTOR	ERJ3GEYJ 102 V (1 kΩ)
R97	7030003440	S. RESISTOR	ERJ3GEYJ 102 V (1 kΩ)
R98	7030003440	S. RESISTOR	ERJ3GEYJ 102 V (1 kΩ)
R99	7030003440	S. RESISTOR	ERJ3GEYJ 102 V (1 kΩ)
R101	7080001250	RESISTOR	CRH100X R-02J 22 Ω (220)
R103	7030003640	S. RESISTOR	ERJ3GEYJ 473 V (47 kΩ)
R104	7030003640	S. RESISTOR	ERJ3GEYJ 473 V (47 kΩ)
R105	7030003640	S. RESISTOR	ERJ3GEYJ 473 V (47 kΩ)
R106	7030003640	S. RESISTOR	ERJ3GEYJ 473 V (47 kΩ)
R107	7030003640	S. RESISTOR	ERJ3GEYJ 473 V (47 kΩ)
R108	7030003640	S. RESISTOR	ERJ3GEYJ 473 V (47 kΩ)
R109	7030003660	S. RESISTOR	ERJ3GEYJ 683 V (68 kΩ)
R110	7030003780	S. RESISTOR	ERJ3GEYJ 684 V (680 kΩ)
R116	7030003320	S. RESISTOR	ERJ3GEYJ 101 V (100 Ω)
R117	7030003640	S. RESISTOR	ERJ3GEYJ 473 V (47 kΩ)
R118	7030003280	S. RESISTOR	ERJ3GEYJ 470 V (47 Ω)
R119	7030003640	S. RESISTOR	ERJ3GEYJ 473 V (47 kΩ)
R120	7030003640	S. RESISTOR	ERJ3GEYJ 473 V (47 kΩ)
R121	7030003360	S. RESISTOR	ERJ3GEYJ 221 V (220 Ω)
R126	7030003520	S. RESISTOR	ERJ3GEYJ 472 V (4.7 kΩ)
R127	7030003400	S. RESISTOR	ERJ3GEYJ 471 V (470 Ω)
R132	7030005400	S. RESISTOR	RR0816P-202-D (2 kΩ)
R133	7030005390	S. RESISTOR	RR0816P-102-D (1 kΩ)
R134	7030005390	S. RESISTOR	RR0816P-102-D (1 kΩ)
R135	7030005390	S. RESISTOR	RR0816P-102-D (1 kΩ)
R136	7030005390	S. RESISTOR	RR0816P-102-D (1 kΩ)
R137	7030005390	S. RESISTOR	RR0816P-102-D (1 kΩ)
R138	7030005390	S. RESISTOR	RR0816P-102-D (1 kΩ)
R139	7030005380	S. RESISTOR	RR0816P-102-B (1 kΩ)
R140	7030005380	S. RESISTOR	RR0816P-102-B (1 kΩ)
R141	7030005380	S. RESISTOR	RR0816P-102-B (1 kΩ)
R142	7030005380	S. RESISTOR	RR0816P-102-B (1 kΩ)
R143	7030005380	S. RESISTOR	RR0816P-102-B (1 kΩ)
R144	7030005400	S. RESISTOR	RR0816P-202-D (2 kΩ)
R145	7030005400	S. RESISTOR	RR0816P-202-D (2 kΩ)
R146	7030005400	S. RESISTOR	RR0816P-202-D (2 kΩ)
R147	7030005400	S. RESISTOR	RR0816P-202-D (2 kΩ)
R148	7030005400	S. RESISTOR	RR0816P-202-D (2 kΩ)
R149	7030005400	S. RESISTOR	RR0816P-202-D (2 kΩ)
R150	7030005370	S. RESISTOR	RR0816P-202-B (2 kΩ)
R151	7030005370	S. RESISTOR	RR0816P-202-B (2 kΩ)
R152	7030005370	S. RESISTOR	RR0816P-202-B (2 kΩ)
R153	7030005370	S. RESISTOR	RR0816P-202-B (2 kΩ)
R154	7030005370	S. RESISTOR	RR0816P-202-B (2 kΩ)
R155	7030005400	S. RESISTOR	RR0816P-202-D (2 kΩ)
R156	7030003280	S. RESISTOR	ERJ3GEYJ 470 V (47 Ω)
R157	7010001320	RESISTOR	R25XJ 22 kΩ
R158	7030003320	S. RESISTOR	ERJ3GEYJ 101 V (100 Ω)
R159	7030003560	S. RESISTOR	ERJ3GEYJ 103 V (10 kΩ)
R160	7030003560	S. RESISTOR	ERJ3GEYJ 103 V (10 kΩ)
R161	7030003360	S. RESISTOR	ERJ3GEYJ 221 V (220 Ω)
R162	7030003500	S. RESISTOR	ERJ3GEYJ 332 V (3.3 kΩ)
R163	7030003500	S. RESISTOR	ERJ3GEYJ 332 V (3.3 kΩ)
R164	7030003440	S. RESISTOR	ERJ3GEYJ 102 V (1 kΩ)
R165	7030003800	S. RESISTOR	ERJ3GEYJ 105 V (1 MΩ)

S.=Surface mount

[PLL UNIT]

REF. NO.	ORDER NO.	DESCRIPTION	
R166	7030003800	S. RESISTOR	ERJ3GEYJ 105 V (1 MΩ)
R167	7010004140	RESISTOR	R20J 390 Ω
R168	7030003400	S. RESISTOR	ERJ3GEYJ 471 V (470 Ω)
R169	7030003280	S. RESISTOR	ERJ3GEYJ 470 V (47 Ω)
C1	4510004990	ELECTROLYTIC	16 MV 100 HC
C2	4510005210	ELECTROLYTIC	50 MV 1 SWNP
C3	4030006870	S. CERAMIC	C1608 JB 1H 222K-T-A
C4	4510003840	ELECTROLYTIC	50 MV 1 SW
C5	4510004990	ELECTROLYTIC	16 MV 100 HC
C7	4030008920	S. CERAMIC	C1608 JB 1C 473K-T-A
C8	4510003790	ELECTROLYTIC	16 MV 10 SW
C9	4510003790	ELECTROLYTIC	16 MV 10 SW
C10	4030008920	S. CERAMIC	C1608 JB 1C 473K-T-A
C12	4030008920	S. CERAMIC	C1608 JB 1C 473K-T-A
C13	4030008920	S. CERAMIC	C1608 JB 1C 473K-T-A
C14	4030007380	S. CERAMIC	C1608 PH 1H 820J-T-A
C15	4030008300	S. CERAMIC	C1608 UJ 1H 330J-T-A
C16	4610001260	S. TRIMMER	ECR-JA020 E12W
C17	4030006880	S. CERAMIC	C1608 JB 1H 472K-T-A
C18	4030006750	S. CERAMIC	C1608 SL 1H 101J-T-A
C19	4030006880	S. CERAMIC	C1608 JB 1H 472K-T-A
C20	4030006630	S. CERAMIC	C1608 SL 1H 150J-T-A
C21	4510004990	ELECTROLYTIC	16 MV 100 HC
C22	4030006880	S. CERAMIC	C1608 JB 1H 472K-T-A
C23	4030006510	S. CERAMIC	C1608 SL 1H 0R5C-T-A
C24	4030006610	S. CERAMIC	C1608 SL 1H 100D-T-A
C25	4030007380	S. CERAMIC	C1608 PH 1H 820J-T-A
C26	4030006750	S. CERAMIC	C1608 SL 1H 101J-T-A
C27	4030006860	S. CERAMIC	C1608 JB 1H 102K-T-A
C28	4030006900	S. CERAMIC	C1608 JB 1E 103K-T-A
C29	4030006880	S. CERAMIC	C1608 JB 1H 472K-T-A
C30	4030006880	S. CERAMIC	C1608 JB 1H 472K-T-A
C31	4030006880	S. CERAMIC	C1608 JB 1H 472K-T-A
C32	4030008920	S. CERAMIC	C1608 JB 1C 473K-T-A
C33	4030008920	S. CERAMIC	C1608 JB 1C 473K-T-A
C34	4030009000	S. CERAMIC	C2012 JB 1C 224K-T-A
C35	4030008920	S. CERAMIC	C1608 JB 1C 473K-T-A
C36	4030006880	S. CERAMIC	C1608 JB 1H 472K-T-A
C37	4030007130	S. CERAMIC	C1608 CH 1H 101J-T-A
C38	4030007020	S. CERAMIC	C1608 CH 1H 120J-T-A
C39	4610001270	S. TRIMMER	ECR-JA010 A12W
C40	4030007110	S. CERAMIC	C1608 CH 1H 680J-T-A
C41	4030006880	S. CERAMIC	C1608 JB 1H 472K-T-A
C42	4030006880	S. CERAMIC	C1608 JB 1H 472K-T-A
C43	4030007030	S. CERAMIC	C1608 CH 1H 150J-T-A
C44	4030007010	S. CERAMIC	C1608 CH 1H 100D-T-A
C45	4030007010	S. CERAMIC	C1608 CH 1H 100D-T-A
C48	4030008920	S. CERAMIC	C1608 JB 1C 473K-T-A
C50	4030008920	S. CERAMIC	C1608 JB 1C 473K-T-A
C51	4030008850	S. CERAMIC	C1608 JB 1C 123K-T-A
C52	4030006870	S. CERAMIC	C1608 JB 1H 222K-T-A
C53	4030009490	S. CERAMIC	C1608 JB 1H 821K-T-A
C54	4030008860	S. CERAMIC	C1608 JB 1C 153K-T-A
C55	4030008870	S. CERAMIC	C1608 JB 1C 183K-T-A
C62	4030007170	S. CERAMIC	C1608 CH 1H 221J-T-A
C63	4030009990	S. CERAMIC	C1608 CH 1H 200J-T-A
C64	4610001270	S. TRIMMER	ECR-JA010 A12W
C65	4030007110	S. CERAMIC	C1608 CH 1H 680J-T-A
C66	4030007020	S. CERAMIC	C1608 CH 1H 120J-T-A
C67	4030007020	S. CERAMIC	C1608 CH 1H 120J-T-A
C68	4030006880	S. CERAMIC	C1608 JB 1H 472K-T-A
C69	4030007110	S. CERAMIC	C1608 CH 1H 680J-T-A
C70	4030007030	S. CERAMIC	C1608 CH 1H 150J-T-A
C71	4610001270	S. TRIMMER	ECR-JA010 A12W
C72	4030007090	S. CERAMIC	C1608 CH 1H 470J-T-A
C73	4030007020	S. CERAMIC	C1608 CH 1H 120J-T-A
C74	4030007020	S. CERAMIC	C1608 CH 1H 120J-T-A
C75	4030006880	S. CERAMIC	C1608 JB 1H 472K-T-A
C76	4030010000	S. CERAMIC	C1608 CH 1H 510J-T-A
C77	4030007020	S. CERAMIC	C1608 CH 1H 120J-T-A
C78	4610001170	S. TRIMMER	ECR-JA006 A12W
C79	4030007090	S. CERAMIC	C1608 CH 1H 470J-T-A
C80	4030007020	S. CERAMIC	C1608 CH 1H 120J-T-A

[PLL UNIT]

REF. NO.	ORDER NO.	DESCRIPTION	
C81	4030006990	S. CERAMIC	C1608 CH 1H 080D-T-A
C82	4030006880	S. CERAMIC	C1608 JB 1H 472K-T-A
C84	4030007090	S. CERAMIC	C1608 CH 1H 470J-T-A
C85	4030006970	S. CERAMIC	C1608 CH 1H 060D-T-A
C86	4610001170	S. TRIMMER	ECR-JA006 A12W
C87	4030007070	S. CERAMIC	C1608 CH 1H 303J-T-A
C88	4030007020	S. CERAMIC	C1608 CH 1H 120J-T-A
C89	4030006970	S. CERAMIC	C1608 CH 1H 060D-T-A
C90	4030006880	S. CERAMIC	C1608 JB 1H 472K-T-A
C91	4030008920	S. CERAMIC	C1608 JB 1C 473K-T-A
C92	4510004990	ELECTROLYTIC	16 MV 100 HC
C93	4030006880	S. CERAMIC	C1608 JB 1H 472K-T-A
C94	4030006540	S. CERAMIC	C1608 SL 1H 030C-T-A
C95	4030006860	S. CERAMIC	C1608 JB 1H 472K-T-A
C96	4030006880	S. CERAMIC	C1608 JB 1H 472K-T-A
C97	4030006540	S. CERAMIC	C1608 SL 1H 030C-T-A
C98	4030006860	S. CERAMIC	C1608 JB 1H 102K-T-A
C99	4030006880	S. CERAMIC	C1608 JB 1H 102K-T-A
C100	4030006540	S. CERAMIC	C1608 SL 1H 030C-T-A
C101	4030006860	S. CERAMIC	C1608 JB 1H 102K-T-A
C102	4030006880	S. CERAMIC	C1608 JB 1H 472K-T-A
C103	4030006540	S. CERAMIC	C1608 SL 1H 030C-T-A
C104	4030006860	S. CERAMIC	C1608 JB 1H 102K-T-A
C105	4030006880	S. CERAMIC	C1608 JB 1H 472K-T-A
C106	4030008920	S. CERAMIC	C1608 JB 1C 473K-T-A
C107	4030006880	S. CERAMIC	C1608 JB 1H 472K-T-A
C108	4030006880	S. CERAMIC	C1608 JB 1H 472K-T-A
C109	4030006880	S. CERAMIC	C1608 JB 1H 472K-T-A
C110	4030006860	S. CERAMIC	C1608 JB 1H 102K-T-A
C111	4030006860	S. CERAMIC	C1608 JB 1H 102K-T-A
C112	4030006720	S. CERAMIC	C1608 SL 1H 560J-T-A
C113	4030006840	S. CERAMIC	C1608 SL 1H 391J-T-A
C114	4030006700	S. CERAMIC	C1608 SL 1H 390J-T-A
C115	4030009230	S. CERAMIC	C1608 SL 1H 240J-T-A
C116	4030006590	S. CERAMIC	C1608 SL 1H 080D-T-A
C117	4030006710	S. CERAMIC	C1608 SL 1H 470J-T-A
C118	4030006880	S. CERAMIC	C1608 JB 1H 472K-T-A
C119	4030006860	S. CERAMIC	C1608 JB 1H 102K-T-A
C120	4030006880	S. CERAMIC	C1608 JB 1H 472K-T-A
C124	4030006880	S. CERAMIC	C1608 JB 1H 472K-T-A
C126	4030006880	S. CERAMIC	C1608 JB 1H 472K-T-A
C127	4030006860	S. CERAMIC	C1608 JB 1H 102K-T-A
C128	4030006880	S. CERAMIC	C1608 JB 1H 472K-T-A
C129	4030008960	S. CERAMIC	C2012 JB 1C 104K-T-A
C130	4030006860	S. CERAMIC	C1608 JB 1H 102K-T-A
C132	4030006750	S. CERAMIC	C1608 SL 1H 101J-T-A
C134	4030006720	S. CERAMIC	C1608 SL 1H 560J-T-A
C135	4030006550	S. CERAMIC	C1608 SL 1H 040C-T-A
C136	4030006620	S. CERAMIC	C1608 SL 1H 120J-T-A
C137	4030006730	S. CERAMIC	C1608 SL 1H 680J-T-A
C138	4030006720	S. CERAMIC	C1608 SL 1H 560J-T-A
C139	4030008920	S. CERAMIC	C1608 JB 1C 473K-T-A
C141	4030008920	S. CERAMIC	C1608 JB 1C 473K-T-A
C143	4030008920	S. CERAMIC	C1608 JB 1C 473K-T-A
C144	4030008920	S. CERAMIC	C1608 JB 1C 473K-T-A
C145	4030008920	S. CERAMIC	C1608 JB 1C 473K-T-A
C146	4030008920	S. CERAMIC	C1608 JB 1C 473K-T-A
C147	4030008920	S. CERAMIC	C1608 JB 1C 473K-T-A
C148	4030008920	S. CERAMIC	C1608 JB 1C 473K-T-A
C149	4030008920	S. CERAMIC	C1608 JB 1C 473K-T-A
C150	4030008920	S. CERAMIC	C1608 JB 1C 473K-T-A
C151	4030008920	S. CERAMIC	C1608 JB 1C 473K-T-A
C152	4030008920	S. CERAMIC	C1608 JB 1C 473K-T-A
C153	4030008920	S. CERAMIC	C1608 JB 1C 473K-T-A
C155	4030008920	S. CERAMIC	C1608 JB 1C 473K-T-A
C156	4030006660	S. CERAMIC	C1608 SL 1H 220J-T-A
C157	4030006700	S. CERAMIC	C1608 SL 1H 390J-T-A
C158	4030006860	S. CERAMIC	C1608 JB 1H 102K-T-A
C159	4030006860	S. CERAMIC	C1608 JB 1H 102K-T-A
C160	4030006880	S. CERAMIC	C1608 JB 1H 472K-T-A
C161	4030006880	S. CERAMIC	C1608 JB 1H 472K-T-A
C162	4030006860	S. CERAMIC	C1608 JB 1H 102K-T-A
C163	4030006860	S. CERAMIC	C1608 JB 1H 102K-T-A

S.=Surface mount

[PLL UNIT]

REF. NO.	ORDER NO.	DESCRIPTION	
J3	6510016030	CONNECTOR	52089-1620
J4	6510007020	CONNECTOR	TMP-J01X-V6
EP1	0910039593	PCB	B 3858C (PLL)

[PA UNIT]

REF. NO.	ORDER NO.	DESCRIPTION	
R27	7010003400	RESISTOR	ELR20J 1 kΩ
R29	7510000070	THERMISTOR	ERT-D2FHL 503S
C1	4010000520	CERAMIC	DD108 B 472K 50V
C2	4040000250	BARRIER	UAT 08X 473M
C3	4010000510	CERAMIC	DD106 B 222K 50V
C4	4040000250	BARRIER	UAT 08X 473M
C5	4310000610	MYLAR	50 F2D 472J
C6	4310000610	MYLAR	50 F2D 472J
C8	4320000520	DIP MICA	DM20C152J5-N
C9	4040000170	BARRIER	UAT 05X 682K
C10	4040000170	BARRIER	UAT 05X 682K
C11	4010004120	CERAMIC	DD07 B 102K 500V
C13	4010004070	CERAMIC	DD12 SL 221K 500V
C14	4010004070	CERAMIC	DD12 SL 221K 500V
C15	4320000500	DIP MICA	DM20C122J5-N
C16	4320000220	DIP MICA	DM19C 681J5
C17	4040000250	BARRIER	UAT 08X 473M
C19	4040000250	BARRIER	UAT 08X 473M
C20	4510003910	ELECTROLYTIC	16 MV 47 HW
C21	4040000250	BARRIER	UAT 08X 473M
C22	4010000500	CERAMIC	DD104 B 102K 50V
C23	4040000250	BARRIER	UAT 08X 473M
C24	4040000250	BARRIER	UAT 08X 473M
C25	4040000250	BARRIER	UAT 08X 473M
C26	4510003910	ELECTROLYTIC	16 MV 47 HW
C27	4510004600	ELECTROLYTIC	16 MV 1000 HC
C28	4010000520	CERAMIC	DD108 B 472K 50V
C29	4040000260	BARRIER	UZE 08X 104M
C30	4010000380	CERAMIC	DD107 SL 221J 50V
C31	4040000250	BARRIER	UAT 08X 473M
C32	4510004600	ELECTROLYTIC	16 MV 1000 HC
C33	4010000520	CERAMIC	DD108 B 472K 50V
C34	4010000380	CERAMIC	DD107 SL 221J 50V
C35	4040000260	BARRIER	UZE 08X 104M
C36	4040000170	BARRIER	UAT 05X 682K
C37	4040000170	BARRIER	UAT 05X 682K
C38	4040000250	BARRIER	UAT 08X 473M
C39	4040000250	BARRIER	UAT 08X 473M
C40	4040000250	BARRIER	UAT 08X 473M
C41	4040000250	BARRIER	UAT 08X 473M
C42	4510004600	ELECTROLYTIC	16 MV 1000 HC
C45	4010000520	CERAMIC	DD108 B 472K 50V
C46	4010000520	CERAMIC	DD108 B 472K 50V
C47	4010000520	CERAMIC	DD108 B 472K 50V
C48	4020000250	CYLINDER	UP125 X 472M
F1	5210000130	FUSE	FGB 4A
F2	5220000020	HOLDER	S-N5051
F3	5220000020	HOLDER	S-N5051
J8	6510006790	CONNECTOR	TSL-P03P-V2
J9	6510006790	CONNECTOR	TSL-P03P-V2
J10	6510006790	CONNECTOR	TSL-P03P-V2
J11	6510006790	CONNECTOR	TSL-P03P-V2
J12	6510003080	CONNECTOR	RT01T-1.0B
J13	6510003080	CONNECTOR	RT01T-1.0B
J14	6510004880	CONNECTOR	MR-DS-E 01 [ANT]
EP1	6910000610	BEAD	FSOH050RN01
EP2	6910000610	BEAD	FSOH050RN01
EP5	6910000610	BEAD	FSOH050RN01
EP6	6910000610	BEAD	FSOH050RN01
EP7	6910000600	BEAD	FSOH050RN
EP8	6910000600	BEAD	FSOH050RN
EP9	6910000630	BEAD	FSOH070RN
EP10	6910000630	BEAD	FSOH070RN
EP11	0910039454	PCB	B 3860D (PA)
EP13	6910000310	INSULATION PLATE	B312D INSULATION BUSH
EP14	6910000340	SHEET	P101 KD (Insulating sheet)

[PA UNIT]

REF. NO.	ORDER NO.	DESCRIPTION	
Q1	1530000790	TRANSISTOR	2SC1971
Q2	1530000190	TRANSISTOR	2SC3133
Q3	1530000190	TRANSISTOR	2SC3133
Q4	1530000200	TRANSISTOR	2SC2904
Q5	1530000200	TRANSISTOR	2SC2904
Q6	1540000200	TRANSISTOR	2SD1406 Y
D1	1790000710	VARISTOR	MA29B
D2	1790000710	VARISTOR	MA29B
D3	1790000710	VARISTOR	MA29B
D4	1710000010	DIODE	15CD11
L1	6140001170	COIL	LR-142
L2	6140001300	COIL	LR-155
L3	6140001310	COIL	LR-156
L4	6140002540	COIL	LR-292
L5	6140002030	COIL	LR-230 (SK-10M-15Y 120)
L6	6910000670	COIL	BT01RN1-A61-001
L7	6910000670	COIL	BT01RN1-A61-001
L8	6910000670	COIL	BT01RN1-A61-001
L11	6910000670	COIL	BT01RN1-A61-001
L14	6180001230	COIL	LAL 04NA 8R2K
L17	6910000670	COIL	BT01RN1-A61-001
L18	6910000670	COIL	BT01RN1-A61-001
R1	7010004130	RESISTOR	R20J 330 Ω
R2	7010004110	RESISTOR	R20J 220 Ω
R3	7010003360	RESISTOR	ELR20J 470 Ω
R4	7010004830	RESISTOR	R50XJ 4.7 Ω
R5	7010004120	RESISTOR	R20J 270 Ω
R6	7010003300	RESISTOR	ELR20J 150 Ω
R7	7010004030	RESISTOR	R20J 47 Ω
R8	7010004030	RESISTOR	R20J 47 Ω
R9	7010004730	RESISTOR	R50XJ 120 Ω
R10	7010004730	RESISTOR	R50XJ 120 Ω
R11	7070000320	RESISTOR	CRH100X R-02J 3.3 Ω (3R3)
R12	7070000320	RESISTOR	CRH100X R-02J 3.3 Ω (3R3)
R13	7070000320	RESISTOR	CRH100X R-02J 3.3 Ω (3R3)
R14	7070000320	RESISTOR	CRH100X R-02J 3.3 Ω (3R3)
R15	7070000320	RESISTOR	CRH100X R-02J 3.3 Ω (3R3)
R16	7070000320	RESISTOR	CRH100X R-02J 3.3 Ω (3R3)
R17	7010004650	RESISTOR	R50XJ 10 Ω
R18	7010004650	RESISTOR	R50XJ 10 Ω
R19	7070000520	RESISTOR	CRH300 R-02J 2.7 Ω (2R7)
R20	7010004720	RESISTOR	R50XJ 100 Ω
R21	7310000700	TRIMMER	RH0651CS2J1HA (471)
R22	7010004650	RESISTOR	R50XJ 10 Ω
R23	7010005240	RESISTOR	R50XJ 820 Ω
R24	7310000720	TRIMMER	RH0651CJ3J0CA (222)
R25	7100000640	RESISTOR	5 SI 0.012 Ω (J)
R26	7010003400	RESISTOR	ELR20J 1 kΩ

S.=Surface mount

[FILTER UNIT]

REF. NO.	ORDER NO.	DESCRIPTION	
D1	1710000030	DIODE	1S1555
D2	1710000030	DIODE	1S1555
D3	1710000030	DIODE	1S1555
D4	1710000030	DIODE	1S1555
D5	1710000030	DIODE	1S1555
D6	1710000030	DIODE	1S1555
D7	1710000030	DIODE	1S1555
D8	1790000070	DIODE	1SS237
D9	1790000070	DIODE	1SS237
L1	6140001990	COIL	LR-226
L2	6140002000	COIL	LR-227
L3	6140001780	COIL	LR-214
L4	6140001790	COIL	LR-215
L5	6140001800	COIL	LR-216
L6	6140001800	COIL	LR-216
L7	6140002560	COIL	LR-293
L8	6140002560	COIL	LR-293
L9	6110002920	COIL	LA-481
L10	6110002910	COIL	LA-480
L11	6110002890	COIL	LA-478
L12	6110002900	COIL	LA-479
L13	6140002530	COIL	LR-291
L14	6140002520	COIL	LR-290
L15	6180000900	COIL	LAL 03NA 101K
L16	6180000900	COIL	LAL 03NA 101K
L17	6180000900	COIL	LAL 03NA 101K
L18	6180000900	COIL	LAL 03NA 101K
L19	6180000900	COIL	LAL 03NA 101K
L20	6180000900	COIL	LAL 03NA 101K
L21	6180000900	COIL	LAL 03NA 101K
L22	6180000900	COIL	LAL 03NA 101K
L23	6180000900	COIL	LAL 03NA 101K
L24	6180000880	COIL	LAL 03NA 100K
L25	6180000880	COIL	LAL 03NA 100K
L26	6180000880	COIL	LAL 03NA 100K
L27	6180000880	COIL	LAL 03NA 100K
L28	6180000900	COIL	LAL 03NA 101K
L29	6180000900	COIL	LAL 03NA 101K
L30	6140001810	COIL	LR-217
L31	6170000380	COIL	LW-26
R1	7540000100	ABSORBER	SRH-350L
R2	7010004390	RESISTOR	R20J 33 kΩ
R3	7010003220	RESISTOR	ELR20J 33 Ω
R4	7010004320	RESISTOR	R20J 10 kΩ
R5	7010004320	RESISTOR	R20J 10 kΩ
R6	7010003530	RESISTOR	ELR20J 10 kΩ
R7	7010003530	RESISTOR	ELR20J 10 kΩ
R8	7010003620	RESISTOR	ELR20J 47 kΩ
R9	7010003620	RESISTOR	ELR20J 47 kΩ
C1	4040000250	BARRIER	UAT 08X 473M
C2	4040000250	BARRIER	UAT 08X 473M
C3	4040000250	BARRIER	UAT 08X 473M
C4	4040000250	BARRIER	UAT 08X 473M
C5	4040000250	BARRIER	UAT 08X 473M
C6	4040000250	BARRIER	UAT 08X 473M
C7	4040000250	BARRIER	UAT 08X 473M
C8	4040000250	BARRIER	UAT 08X 473M
C9	4010000520	CERAMIC	DD108 B 472K 50V
C10	4010000520	CERAMIC	DD108 B 472K 50V
C11	4010000520	CERAMIC	DD108 B 472K 50V
C12	4010000520	CERAMIC	DD108 B 472K 50V
C13	4040000250	BARRIER	UAT 08X 473M
C14	4010000330	CERAMIC	DD105 SL 101J 50V
C15	4010000120	CERAMIC	DD104 SL 100D 50V
C16	4010000330	CERAMIC	DD105 SL 101J 50V
C17	4610001000	TRIMMER	CVSSA0701
C18	4010000360	CERAMIC	DD106 SL 181J 50V
C19	4010000450	CERAMIC	DD104 B 331K 50V
C20	4010000460	CERAMIC	DD104 B 471K 50V

[FILTER UNIT]

REF. NO.	ORDER NO.	DESCRIPTION	
C21	4010000460	CERAMIC	DD104 B 471K 50V
C22	4320000520	DIP MICA	DM20C152J5-N
C23	4010004080	CERAMIC	DD12 SL 271K 500V
C24	4010004080	CERAMIC	DD12 SL 271K 500V
C25	4320000510	DIP MICA	DM20C272J5-N
C26	4010004030	CERAMIC	DD10 SL 121K 500V
C27	4320000520	DIP MICA	DM20C152J5-N
C28	4010004070	CERAMIC	DD12 SL 221K 500V
C29	4010004050	CERAMIC	DD12 SL 181K 500V
C30	4010004040	CERAMIC	DD10 SL 121K 500V
C31	4010004070	CERAMIC	DD12 SL 221K 500V
C32	4320000500	DIP MICA	DM20C122J5-N
C33	4010003990	CERAMIC	DD09 SL 680K 500V
C34	4010004070	CERAMIC	DD12 SL 221K 500V
C35	4010004070	CERAMIC	DD12 SL 221K 500V
C36	4010004070	CERAMIC	DD12 SL 221K 500V
C37	4010004050	CERAMIC	DD12 SL 181K 500V
C38	4010004030	CERAMIC	DD10 SL 121K 500V
C39	4010004030	CERAMIC	DD10 SL 121K 500V
C40	4010004070	CERAMIC	DD12 SL 221K 500V
C41	4010004070	CERAMIC	DD12 SL 221K 500V
C42	4010004070	CERAMIC	DD12 SL 221K 500V
C43	4010004680	CERAMIC	DD09 SL 750K 500V
C44	4010004050	CERAMIC	DD12 SL 181K 500V
C45	4010004070	CERAMIC	DD12 SL 221K 500V
C46	4010004060	CERAMIC	DD12 SL 201K 500V
C47	4010004010	CERAMIC	DD09 SL 101K 500V
C48	4010003990	CERAMIC	DD09 SL 680K 500V
C49	4010004040	CERAMIC	DD10 SL 151K 500V
C50	4010003990	CERAMIC	DD09 SL 680K 500V
C51	4010004030	CERAMIC	DD10 SL 121K 500V
C52	4010004010	CERAMIC	DD09 SL 101K 500V
C53	4010003910	CERAMIC	DD06 SL 220K 500V
C54	4010004050	CERAMIC	DD12 SL 181K 500V
C55	4010003980	CERAMIC	DD09 SL 560K 500V
C56	4010004680	CERAMIC	DD09 SL 750K 500V
C57	4010004680	CERAMIC	DD09 SL 750K 500V
C58	4010003960	CERAMIC	DD06 SL 390K 500V
C59	4010004040	CERAMIC	DD10 SL 151K 500V
C60	4010003870	CERAMIC	DD06 SL 120K 500V
C61	4010003970	CERAMIC	DD07 SL 470K 500V
C62	4010004680	CERAMIC	DD09 SL 750K 500V
C63	4010000450	CERAMIC	DD104 B 331K 50V
RL1	6330000180	RELAY	MZ-12HG
RL2	6330000180	RELAY	MZ-12HG
RL3	6330000180	RELAY	MZ-12HG
RL4	6330000180	RELAY	MZ-12HG
RL5	6330000180	RELAY	MZ-12HG
RL6	6330000180	RELAY	MZ-12HG
RL7	6330000180	RELAY	MZ-12HG
RL8	6330000180	RELAY	MZ-12HG
RL9	6330000180	RELAY	MZ-12HG
RL10	6330000180	RELAY	MZ-12HG
RL11	6330000180	RELAY	MZ-12HG
RL12	6330000180	RELAY	MZ-12HG
RL13	6330000720	RELAY	DS1-M-DC12V (AG2013)
J3	6510007020	CONNECTOR	TMP-J01X-V6
W1	7120000010	JUMPER	JPW 02A
W2	7120000020	JUMPER	JPW 02H
W3	7120000010	JUMPER	JPW 02A
EP1	0910039606	PCB	B 3861F (FILTER)

S.=Surface mount

SECTION 7 MECHANICAL PARTS

7-1 FRONT, CABINET PARTS AND ACCESSORIES

• FRONT AND CABINET PARTS

LABEL NUMBER	ORDER NO.	DESCRIPTION	QTY.
①	8110005030	963 U-cover	1
②	8810004320	Screw OH M3×8 ZK BS	12
③	8930028270	963 LCD rubber	1
④	8010014690	963 sub chassis	1
⑤	8810007970	Screw PH BT M3×6 NI	4
⑥	5030000980	LCD LD-BU5637EZ [FUNCTION DISPLAY]	1
⑦	8930028280	963 LCD filter	1
⑧	8930028260	963 LCD holder	1
⑨	8810003350	Setscrew C M3×5	1
⑩	8810003350	Setscrew C M3×5	1
⑪	8610002380	Knob N105 [AF, RIT]	2
⑫	8610002390	Knob N106 [SQL]	1
⑬	2260002010	Switch MSR5-2#1 [POWER]	1
⑭	8810007750	Screw PH B1 M3×18 ZK	1
⑮	8610005770	Knob N148 [CHANNEL SELECTOR]	1
⑯	8930028290	963 key cap	1
⑰	8210009510	963 front panel complete (incl. ⑱-㉑)	1
⑱	8610008690	Button K203 [TUNER]	1
⑲	8610008680	Button K204 [LOCK]	1
㉑	8610008670	Button K205 [RIT, FC etc.]	2
㉑	8810000990	Screw PH B0 M2×5	4
㉒	8810007700	Screw FH B1 M3×6	4
㉓	8930030160	963 A knob sheet	1
㉔	8930030180	963 C knob sheet	1
㉕	8930030170	963 B knob sheet	2
㉖	8510008340	963 plate	1
㉗	2510000670	Speaker VS-50-0827	1
㉘	8930028300	963 SP holder	1
㉙	8810007970	Screw PH BT M3×6 NI	4
㉚	8930030140	963 SP sponge	1
㉛	8110005010	610 bottom cover (complete)	1

Screw abbreviations PH: Pan head FH: Flat head OH: Oval countersunk head
 B0, B1, BT: Self-tapping BS: Brass NI: Nickel ZK: Black

• ACCESSORIES

LABEL NUMBER	ORDER NO.	DESCRIPTION	QTY.
①	8900000220	DC power cable OPC-025 A	1
②	Optional product	HM-36 HAND MICROPHONE	1
③	5210000080	Spare fuse FGB 20A	1
④	5210000130	Spare fuse FGB 4A	1
⑤	8810005500	Screw OH B1 M4×12 CR	2
⑥	8810001650	Screw PH FT M3×6	4

Screw abbreviations PH: Pan head
 OH: Oval countersunk head
 B1: Self-tapping screw

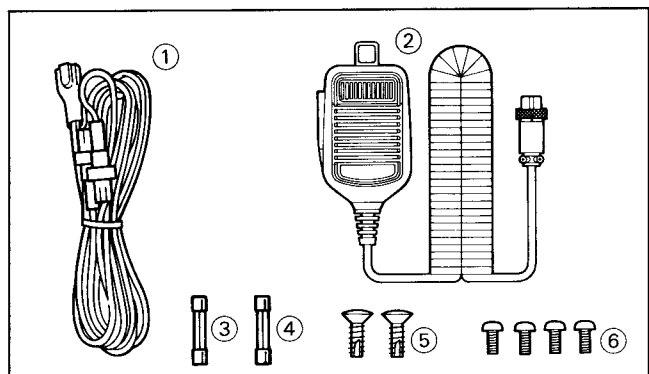

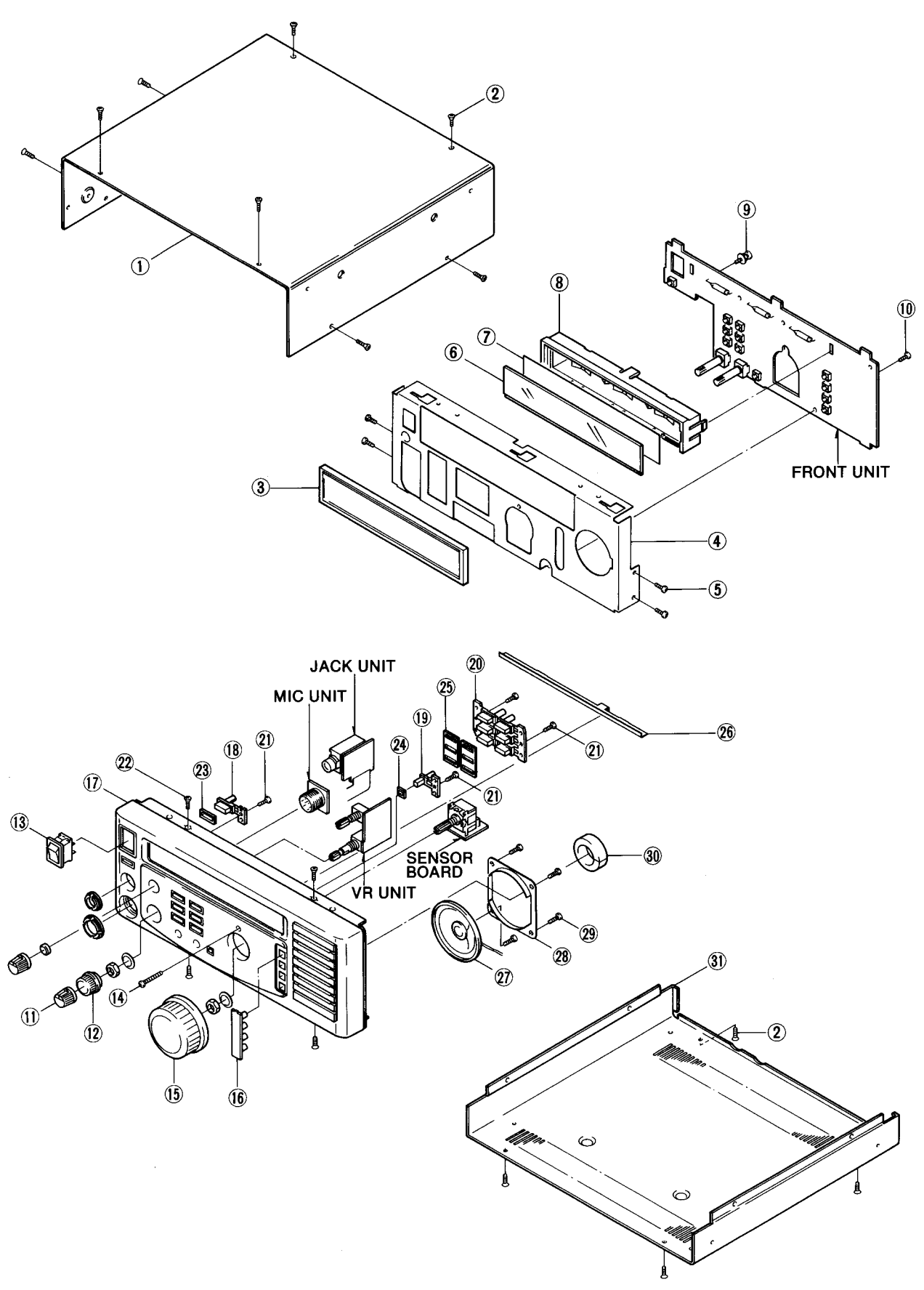

7-2 CHASSIS PARTS

LABEL NUMBER	ORDER NO.	DESCRIPTION	QTY.
①	8510001080	Shield case (A)	1
②	8510000230	220 shield case	1
③	8510005330	Coil shield case	1
④	8510008300	963 DDS shield case	1
⑤	8510001060	Shield case	1
⑥	8510001101	Shield case (A) cover (A) -1	1
⑦	8510008310	963 DDS shield case	1
⑧	8510008540	963 shield case	1
⑨	8510001740	Shield case cover	1
⑩	8510008530	963 shield case	1
⑪	8810003960	Setscrew A M2.6 × 5	4
⑫	8810003160	Setscrew A M3 × 6	3
⑬	8810007970	Screw PH BT M3 × 6 NI	5
⑭	8410001871	963 heatsink-1	1
⑮	8810005540	Screw PH B1 M4 × 10	4
⑯	8600031150	Connector P03×J01CH [TUNER]	1
⑰	8600031240	Connector J01PA [DC 13.8 V]	1
⑱	6510004880	Connector MR-DS-E 01 [ANT]	1
⑲	8810005530	Screw PH ST M2.6 × 6 NI	2
⑳	8810007970	Screw PH BT M3 × 6 NI	32
㉑	8110005020	963 PA cover	1
㉒	6910000310	Insulate bushing B312D	2
㉓	8930005480	Insulating plate I	1
㉔	8810000230	Screw PH M3 × 6	8
㉕	8510008740	963 shield plate	2
㉖	8410000770	AF heatsink-1	1
㉗	8510002200	VCO shield case	1
㉘	8510002280	VCO shield plate (A)	2
㉙	8510000230	220 shield case	1
㉚	8510000241	220 shield case cover -1	1
㉛	8830000100	Nut M3	2
㉜	8810003170	Setscrew A M3 × 8	2
㉝	8010014680	963 main chassis	1
㉞	2710000330	Fan FBA08A12HA	1
㉟	8850000440	Spring washer M5 NI	1
㊱	8830000210	Nut M5 NI BS	1
㊲	8850000150	Flat washer M5 NI BS	3
㊳	8830000360	Wing nut M5 NI [GND]	1

Screw abbreviations PH: Pan head B1, BT, ST: Self-tapping NI: Nickel

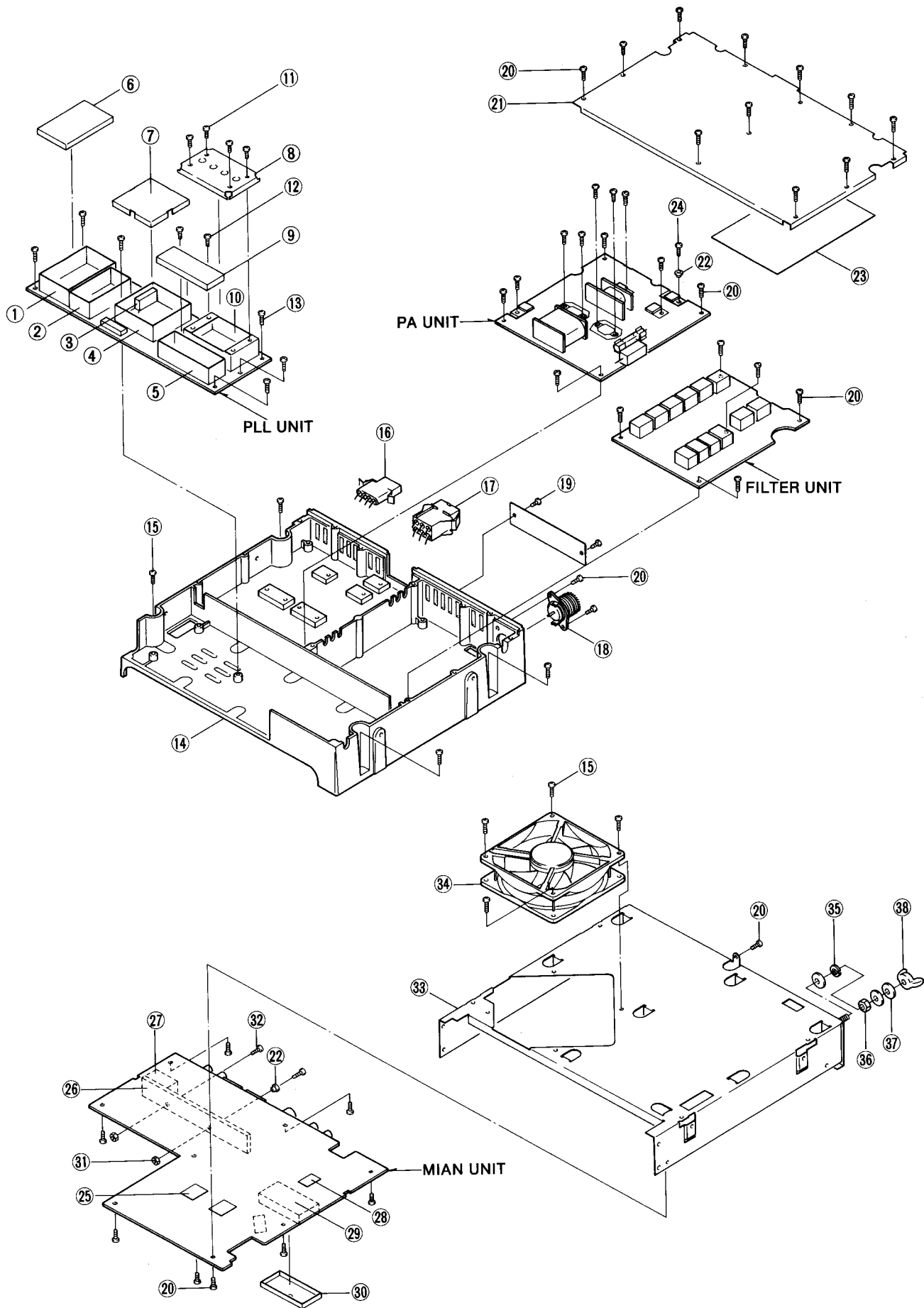

SECTION 8

BOARD LAYOUTS

8-1 MAIN UNIT

2SC4673D
(Symbol: C0)

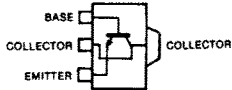

Q1, Q5

2SK882 GR
(Symbol: TG)

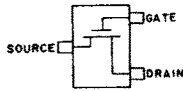

Q4, Q8, Q10, Q12, Q13,
Q45

DTC114EU
(Symbol: 24)

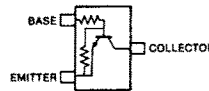

Q6, Q7, Q16, Q18, Q21,
Q29, Q31, Q32, Q38,
Q41, Q47, Q51, Q55,
Q56, Q60, Q63, Q65,
Q69, Q71, Q75, Q77

2SA1576 R
(Symbol: FR)

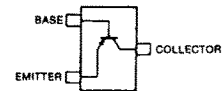

Q11, Q50, Q68

3SK126 0
(Symbol: UC)



Q2, Q3, Q9, Q28, Q46

DTA114EU
(Symbol: 14)

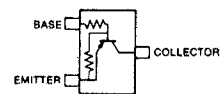

Q14, Q15, Q24, Q30,
Q40, Q61, Q70, Q72

2SB798 DK
(Symbol: DK)

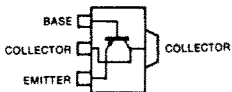

Q17

2SC4081 R
(Symbol: BR)

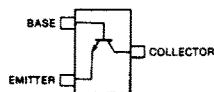

Q25, Q33, Q34, Q35,
Q36, Q37, Q39, Q44,
Q48, Q58, Q59, Q62,
Q64, Q67, Q74

2SD999 CK
(Symbol: CK)

Q52, Q53, Q54; Q66,
Q73

MA862
(Symbol: M11)

D1, D2, D3, D4, D5,
D10, D11, D33, D35,
D36, D38, D41, D42,
D45, D46, D49, D50,
D53, D55, D57

2SK2171 4
(No Symbol)

Q22, Q23, Q26, Q27

2SC4213 B
(Symbol: AB)

Q57, Q76

DAN202U
(Symbol: N)

D6, D7, D8, D9, D18,
D20, D21, D23, D25,
D26, D31, D32, D59,
D61, D62, D64, D67,
D68, D70, D72, D73,
D74, D76, D78, D80,
D81, D83, D85, D86,
D87, D88, D89, D90,
D93, D96, D97, D98,
D99, D100, D104, D108,
D110, D112, D114,
D115, D122, D123,
D127, D128

HSM88ASR
(Symbol: C3)

D15, D65, D71, D91

RD5.1M B2
(Symbol: 512)

D82

RD5.6M B2
(Symbol: 562)

D125

DAP202U
(Symbol: P)

D17, D19, D22, D24,
D63, D84, D101, D102,
D106, D116, D117,
D118, D119, D120,
D121

ND433G
(Symbol: 433)

D124

RD6.2M B2
(Symbol: 622)

D126

8 - 1

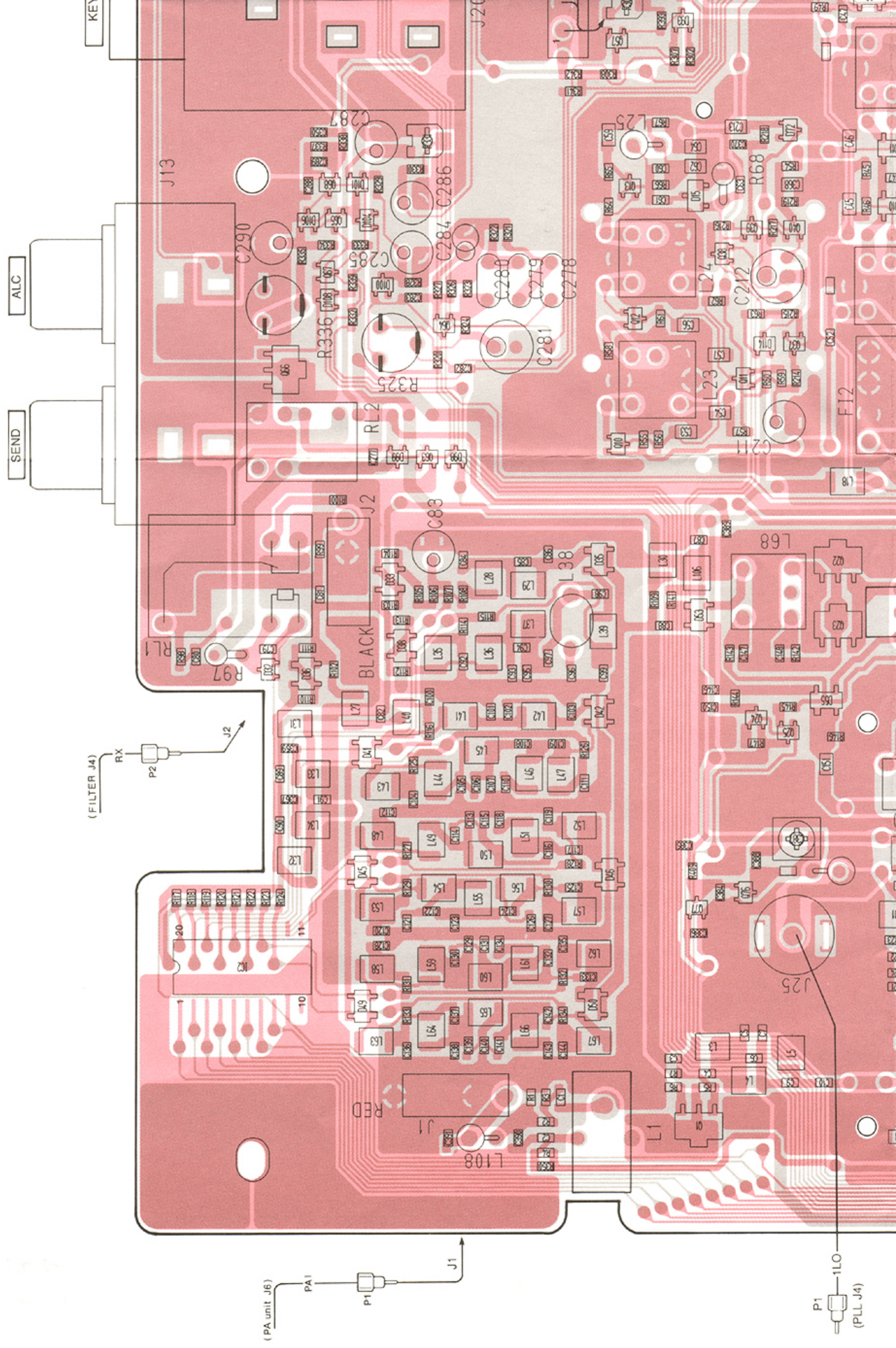

PA unit J6

ALC

SEND

KEY

(PA unit J6)

PA1

P1

J1

ALC

SEND

(FILTER J4)

RX

P2

J2

P1

1L0

(PLL J4)

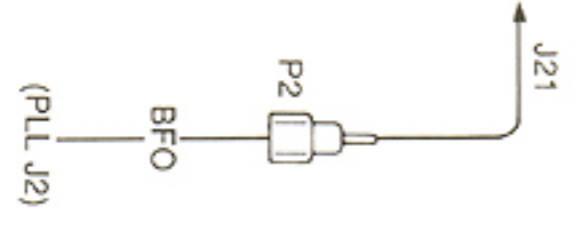
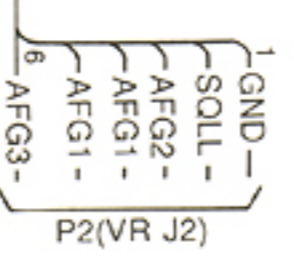
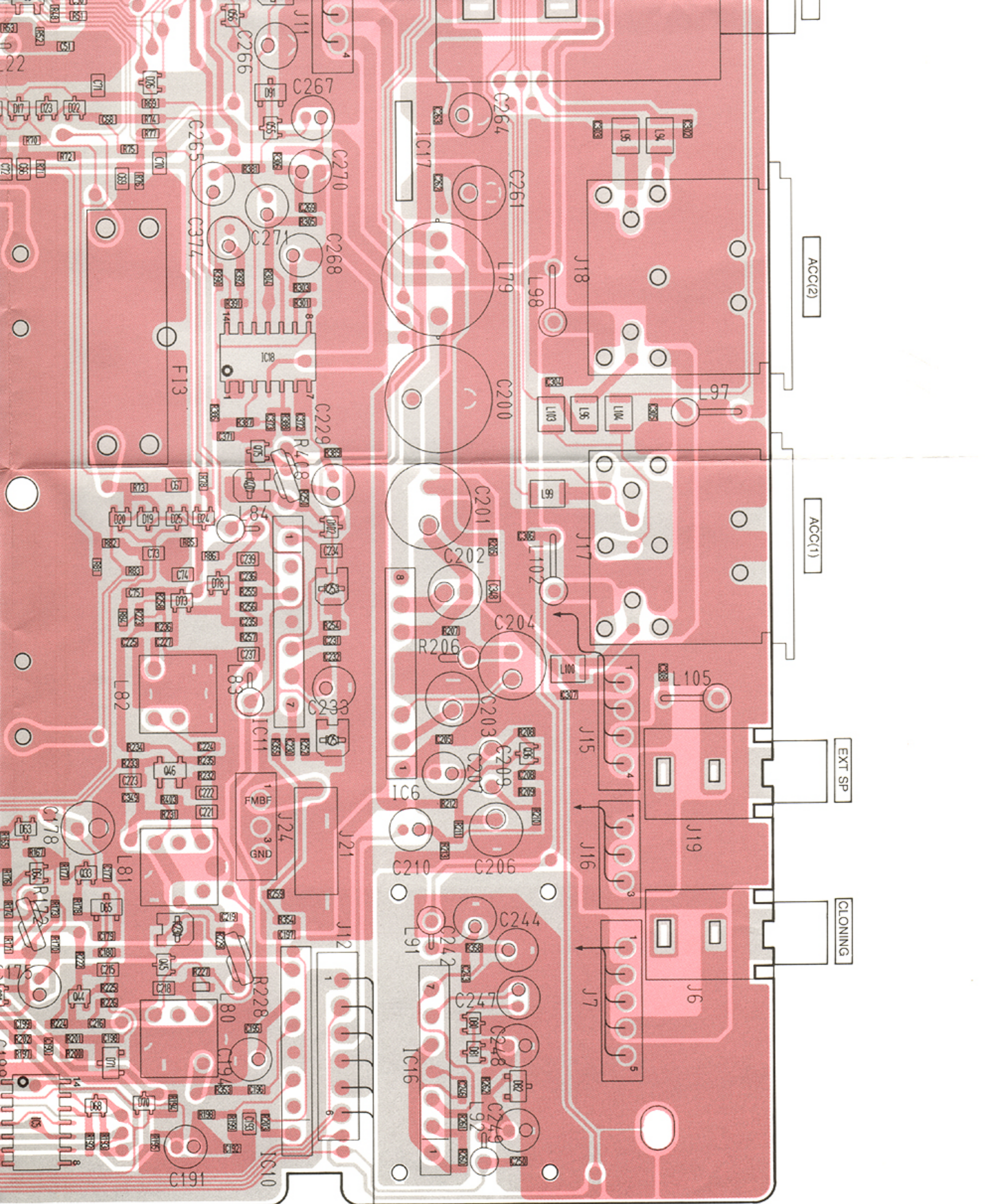

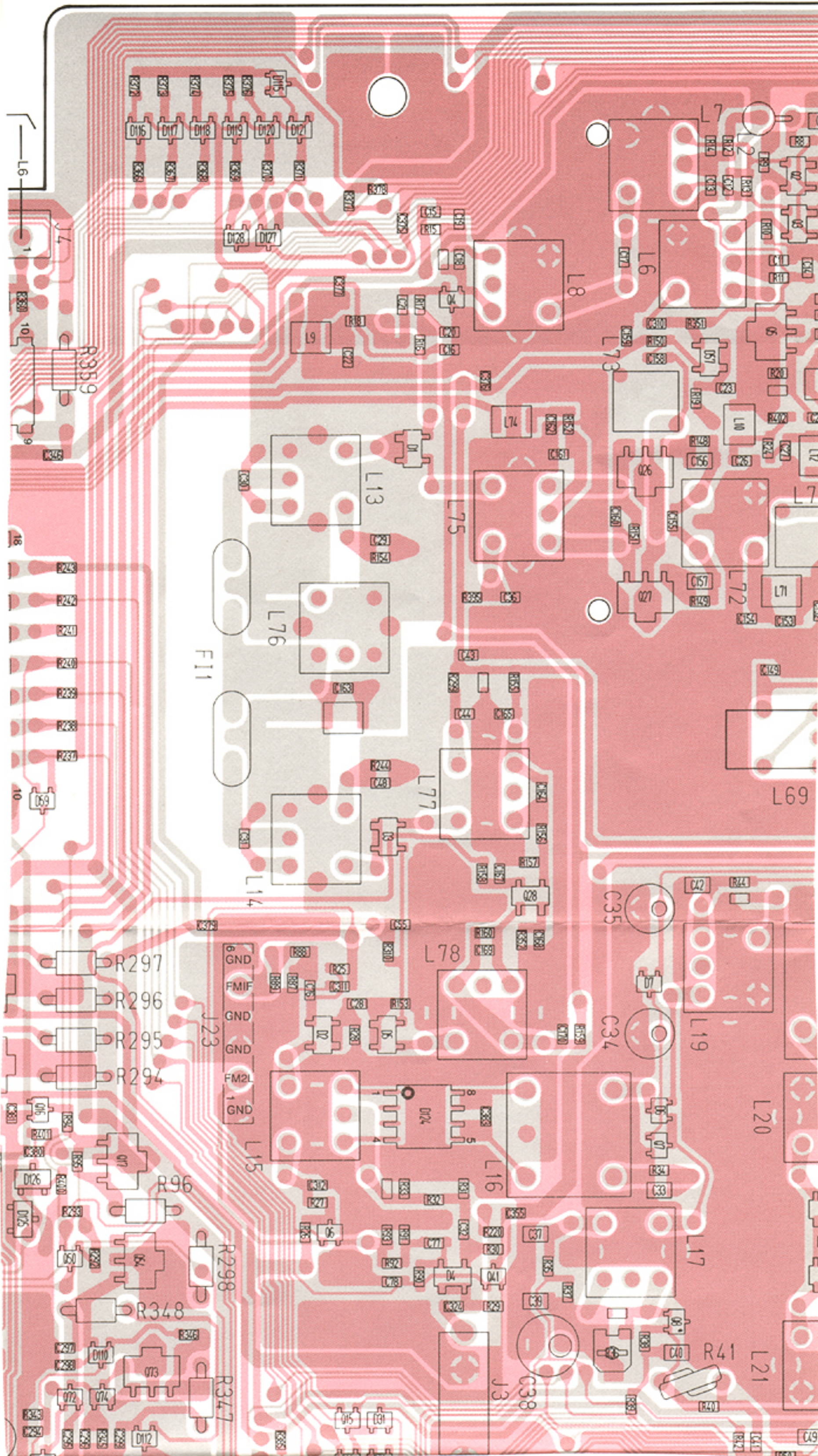

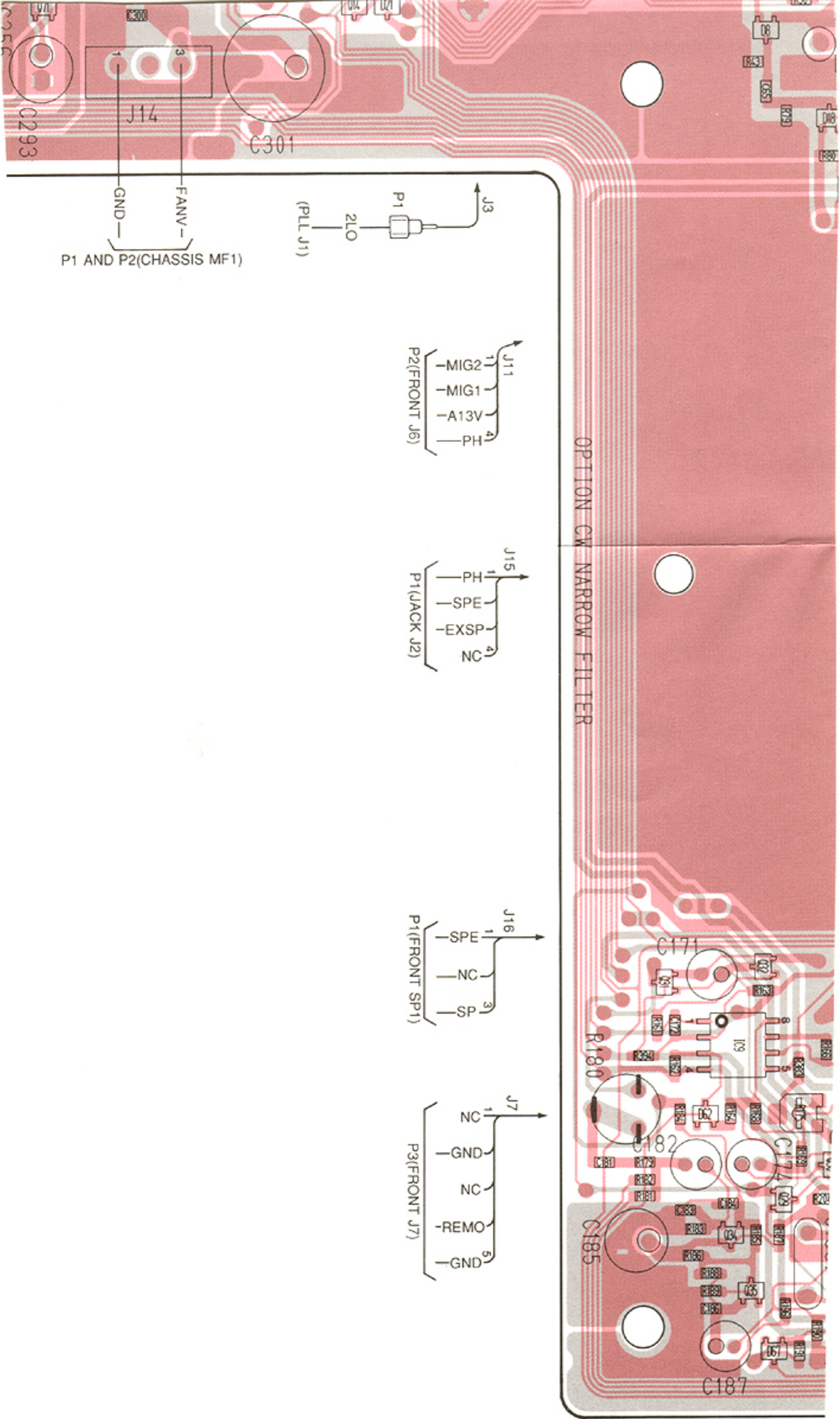

OPTION CW NARROW FILTER

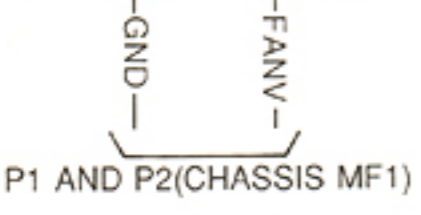
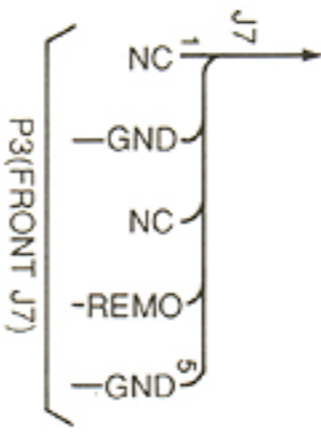
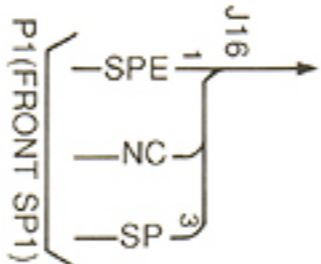
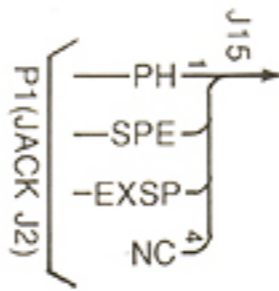
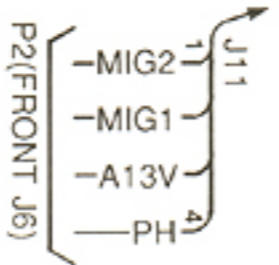
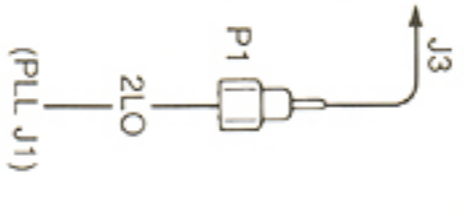

C293

C301

C187

C185

C182

R180

C171

IC3

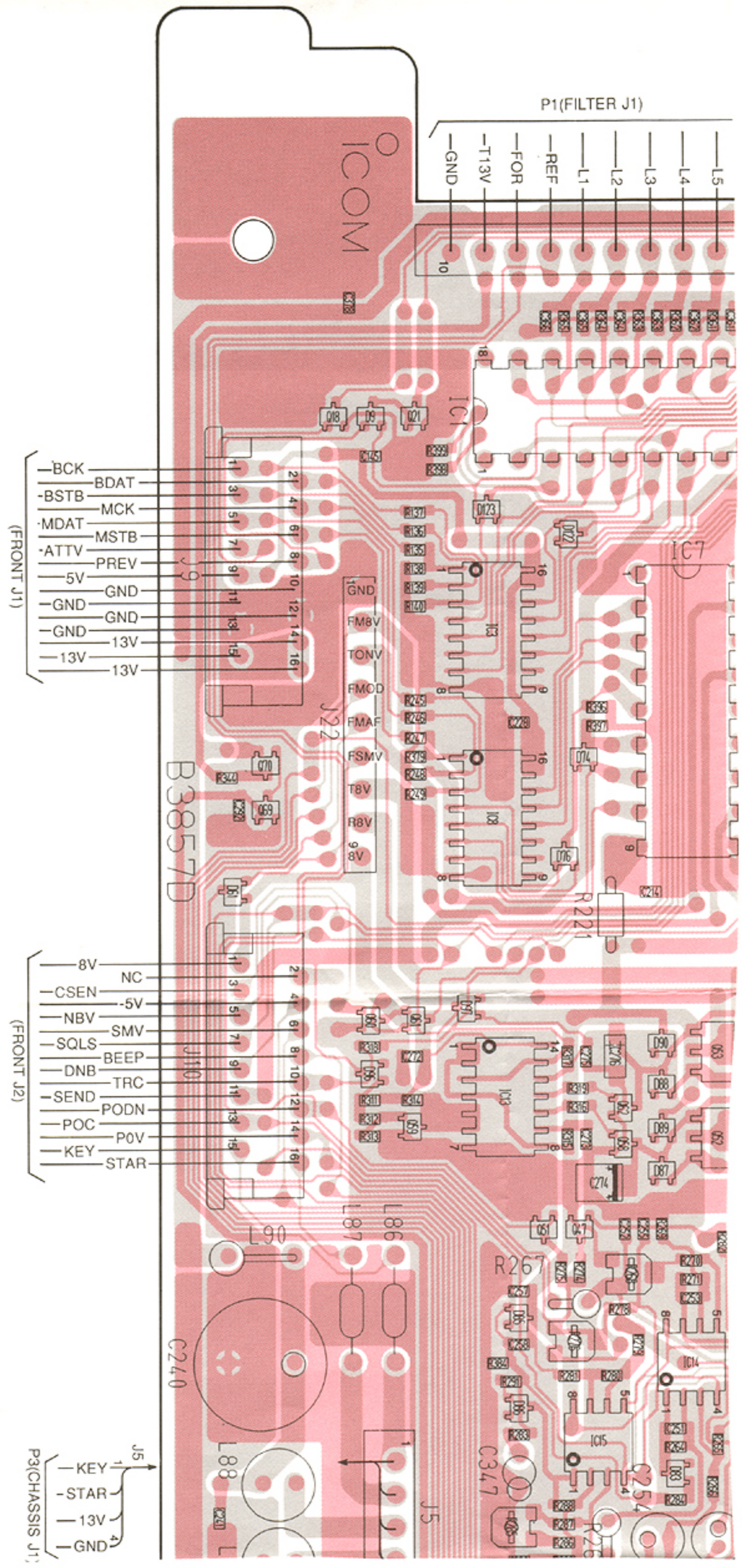

P1(FILTER J1)

- L5
- L4
- L3
- L2
- L1
- REF
- FOR
- T13V
- GND

- BCK
 - BDAT
 - BSTB
 - MCK
 - MDAT
 - MSTB
 - ATTV
 - PREV
 - 5V
 - GND
 - GND
 - 13V
 - 13V
- (FRONT J1)

- GND
- FM8V
- TONV
- FMCD
- FMAF
- FSMV
- T8V
- R8V
- 8V

B3857D

- 8V
 - NC
 - CSEN
 - 5V
 - NBV
 - SMV
 - SQLS
 - BEEP
 - DNB
 - TRC
 - SEND
 - PODN
 - POC
 - P0V
 - KEY
 - STAR
- (FRONT J2)

- KEY
 - STAR
 - 13V
 - GND
- P3(CHASSIS J1)

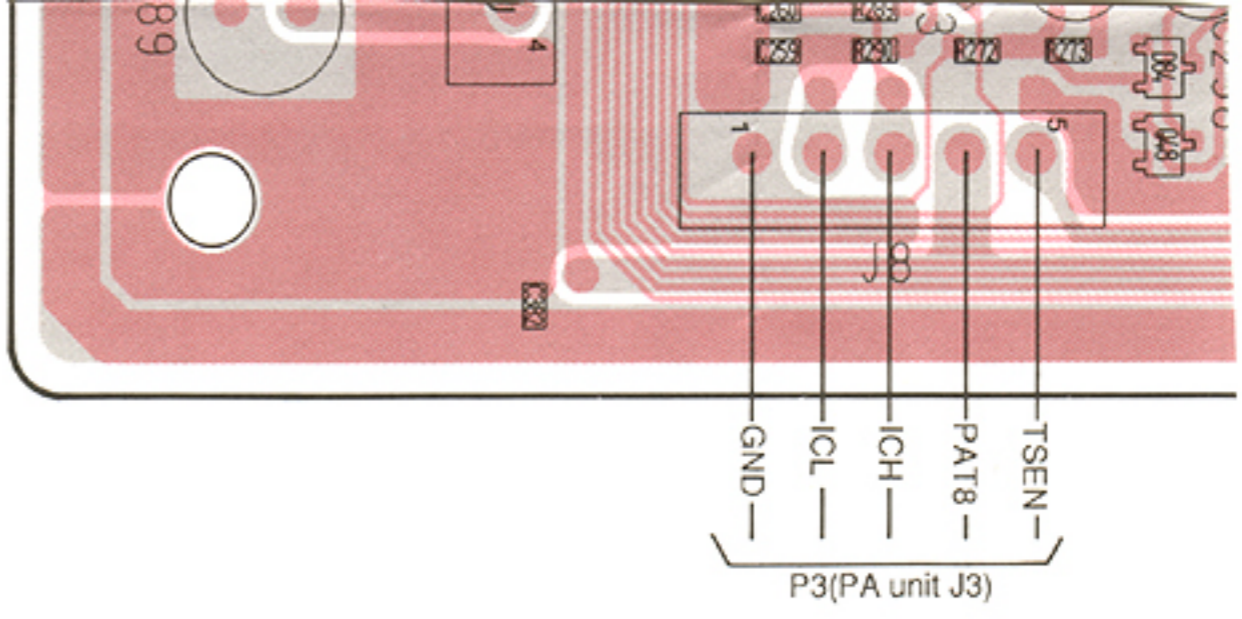

1.3

8-2 FRONT, VR AND JACK UNITS

• FRONT UNIT

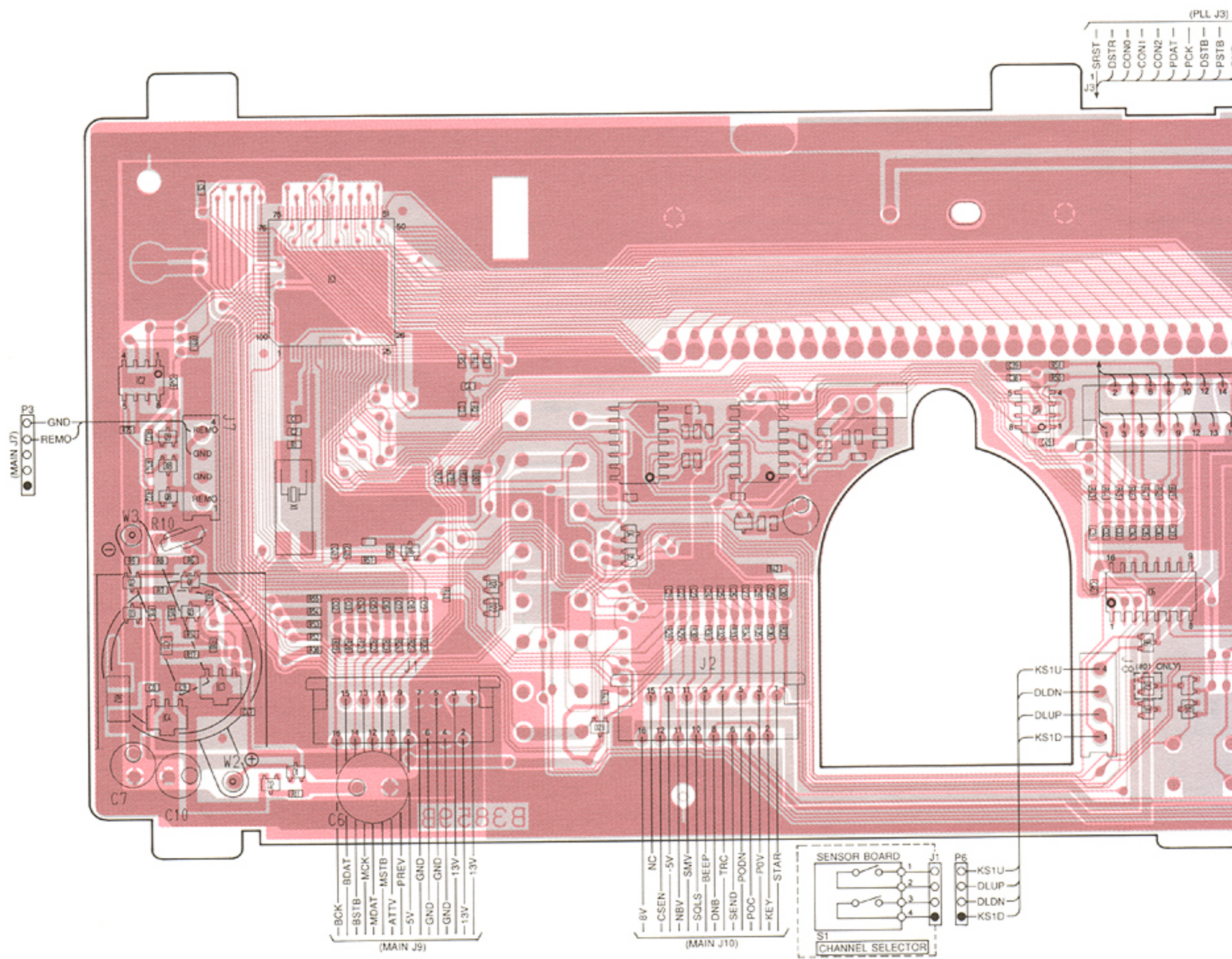

2SA1576 R
(Symbol: FR)

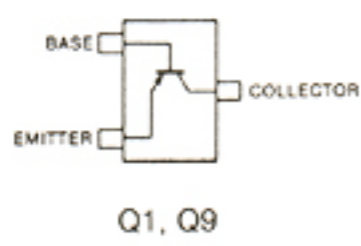

2SB798 DK
(Symbol: DK)

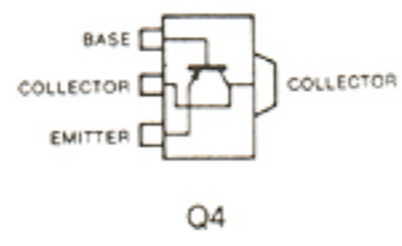

DAP202U
(Symbol: P)

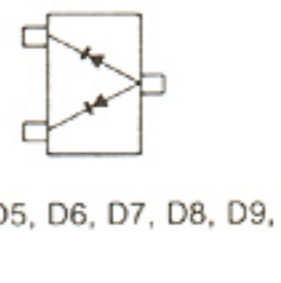

2SC4081 R
(Symbol: BR)

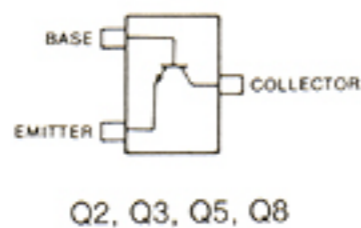

DAN202U
(Symbol: N)

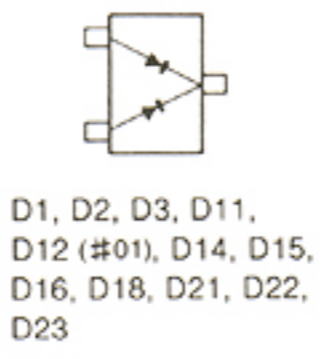

RD5.1M B2
(Symbol: 512)

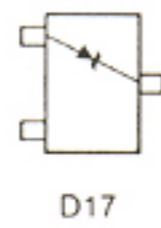

• VR UNIT

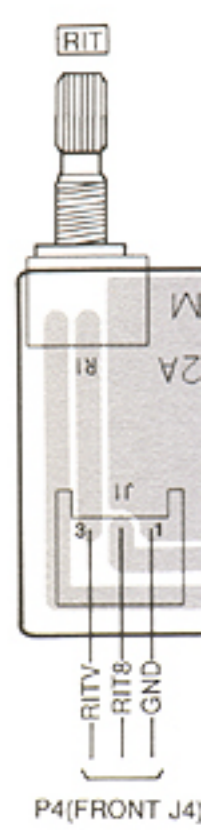

• FRONT UNIT

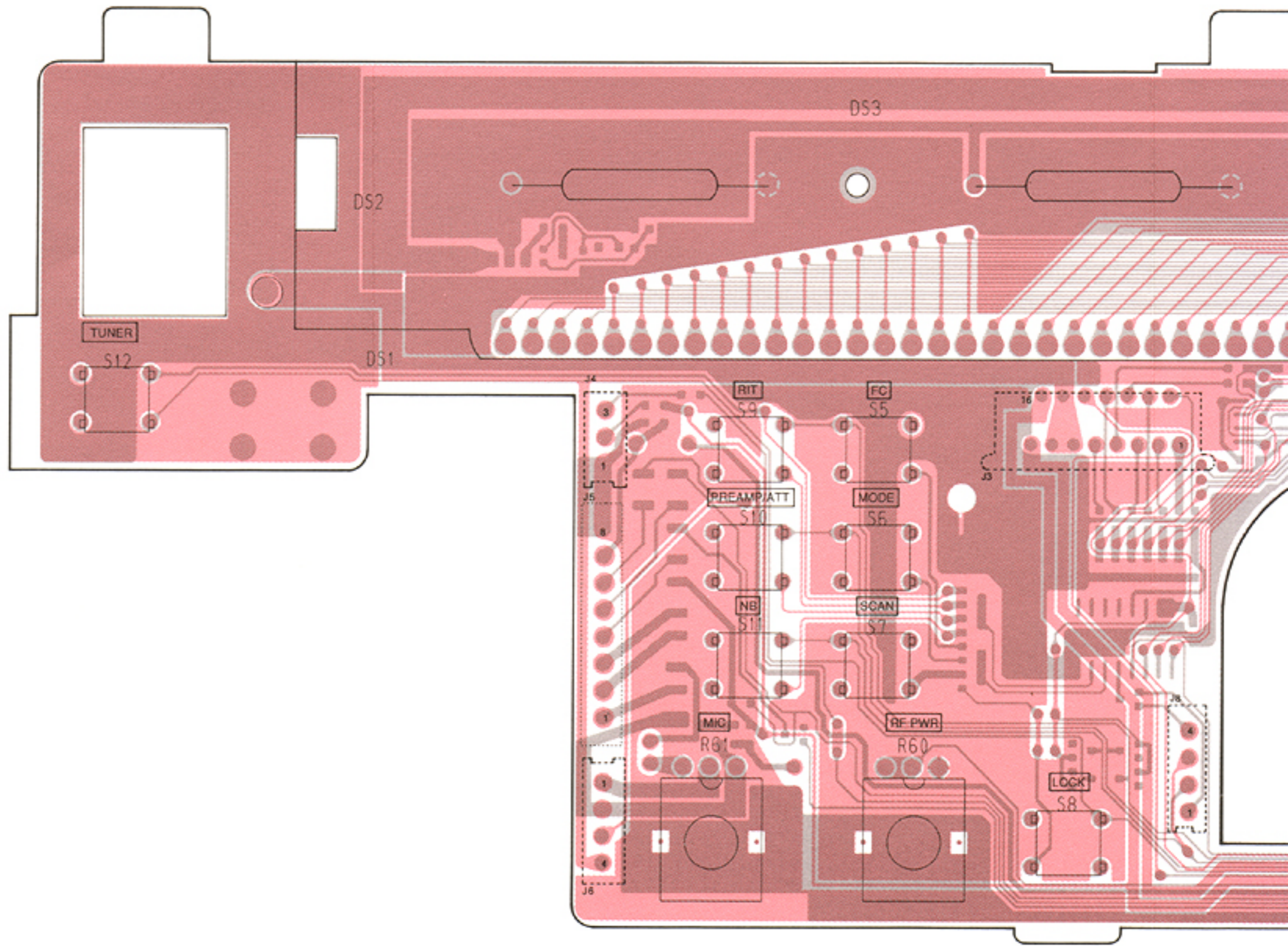

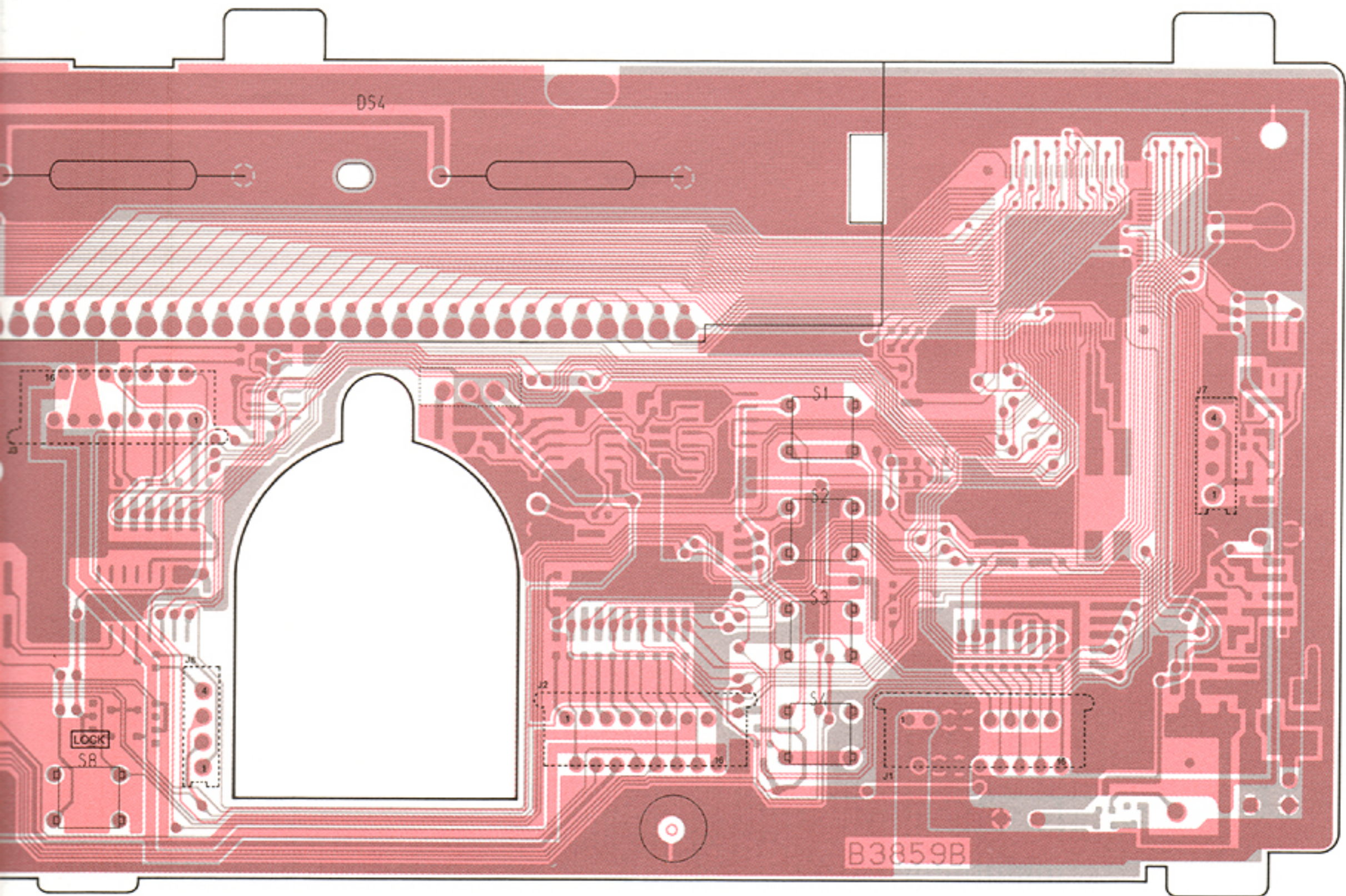

8-3 PLL UNIT

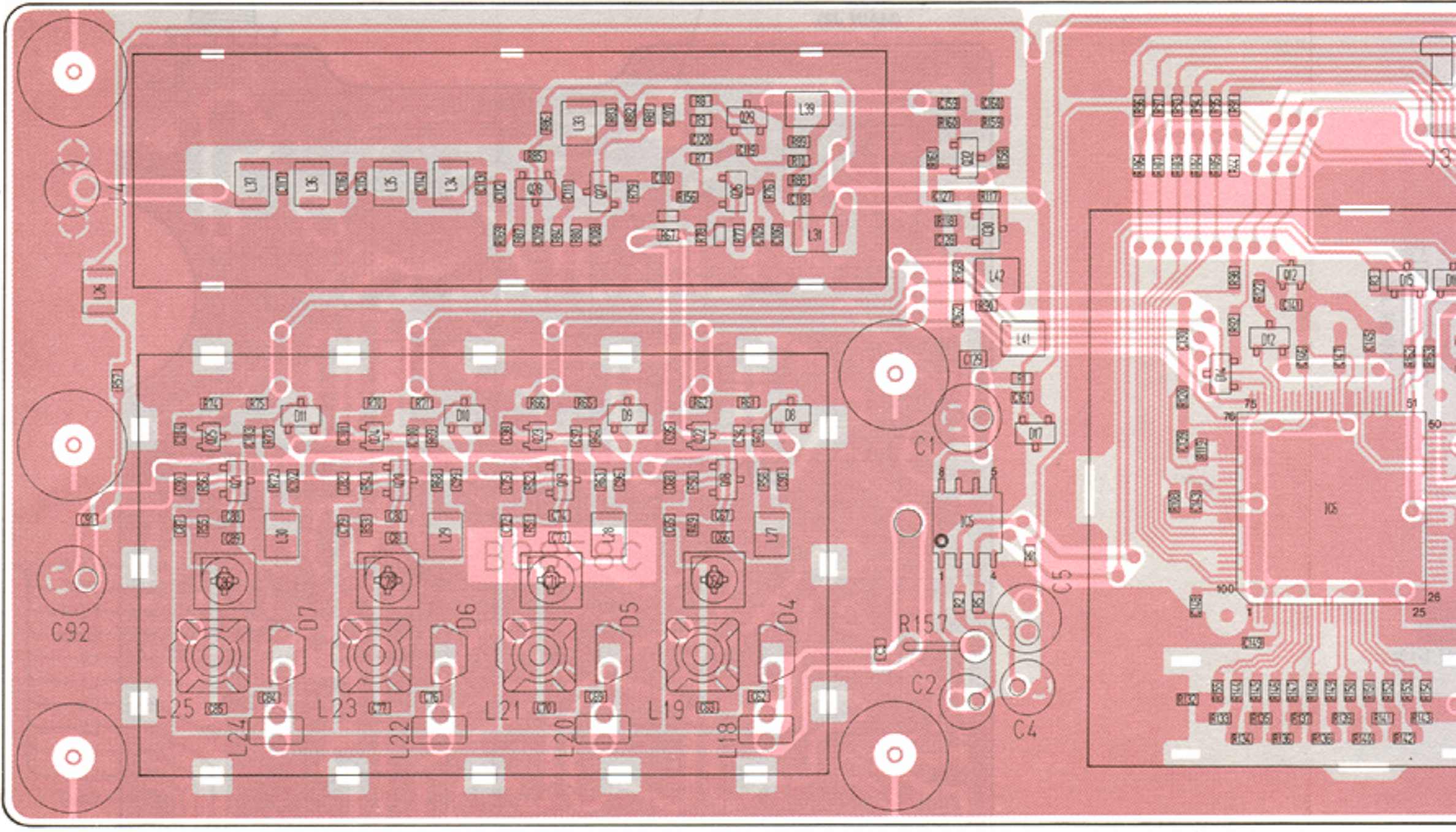
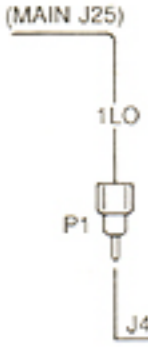

2SC2714 O
(Symbol: Q0)

DTC114EU
(Symbol: 24)

2SC3661
(Symbol: FY)

2SK882 GR
(Symbol: TG)

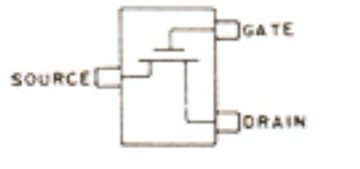
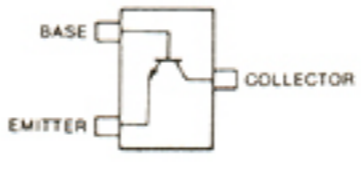
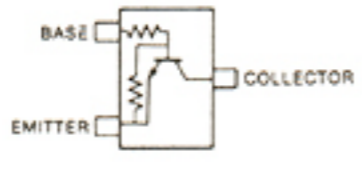
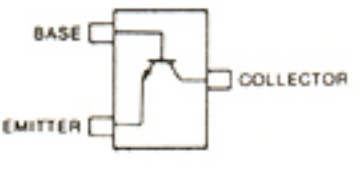

Q9, Q10, Q26, Q27,
Q28, Q29, Q30, Q32

Q12

Q14

Q16

2SC4215 O
(Symbol: Q0)

2SK880 GR
(Symbol: XG)

2SK210 GR
(Symbol: YG)

2SC4081 R
(Symbol: BR)

1SS
(Symbol: BR)

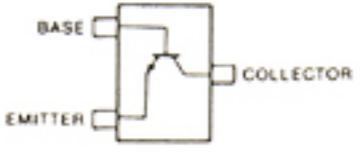
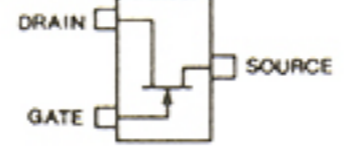
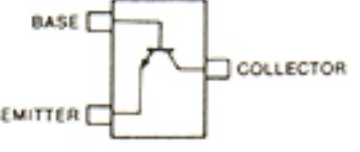

Q11

Q13

Q15, Q18, Q19, Q20,
Q21

Q22, Q23, Q24, Q25

D2, D8,
D12, D13

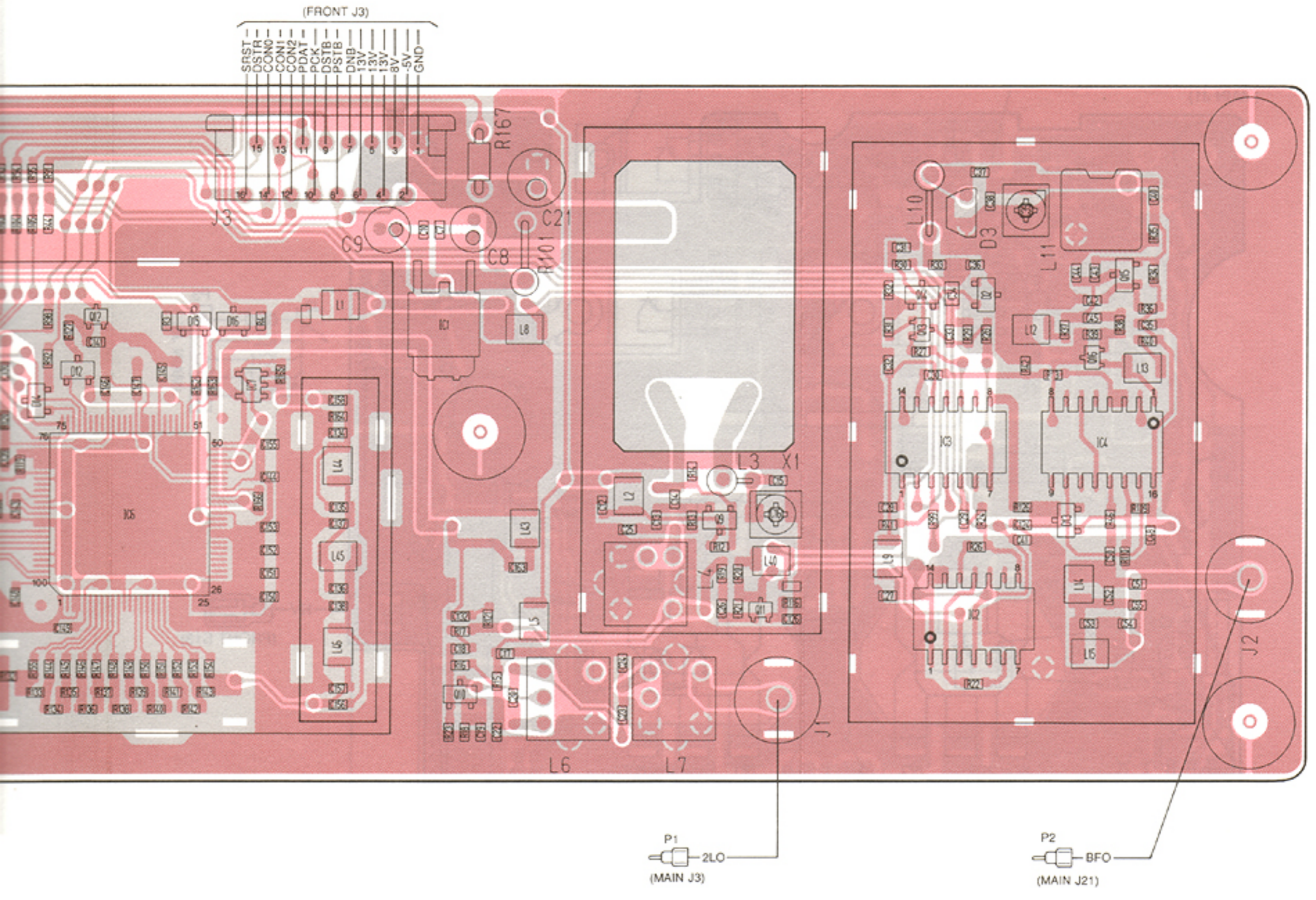

1SS184
(Symbol: B3)

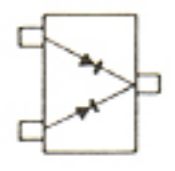

D2, D8, D9, D10, D11,
D12, D14

1SV101



D3, D4, D5, D6, D7

RD3.9M B2
(Symbol: 392)

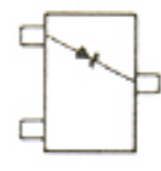

D13

1SS226
(Symbol: C3)

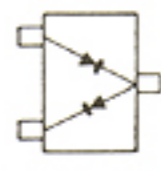

D15, D16, D17

8-4 PA UNIT

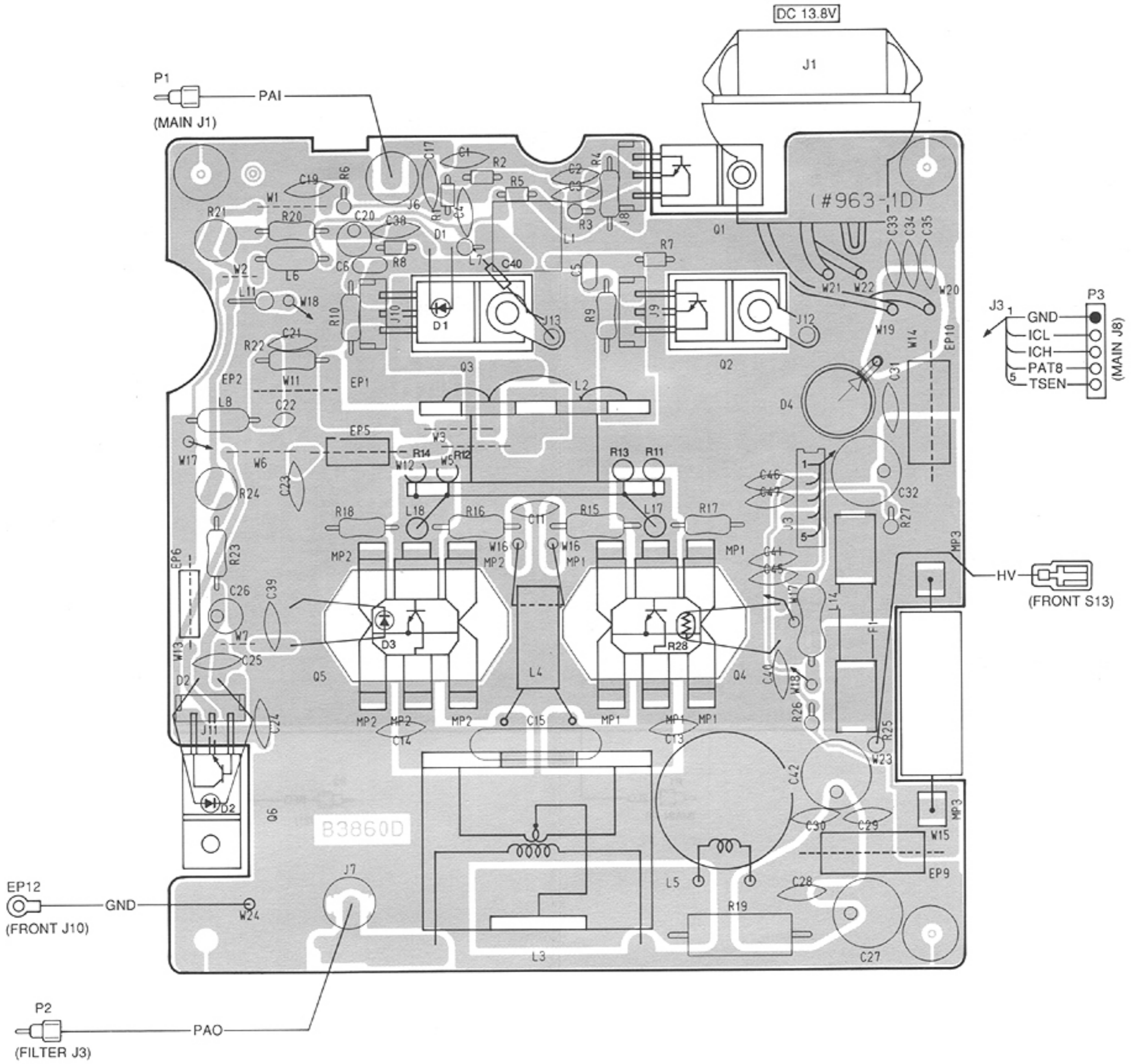

2SC1971

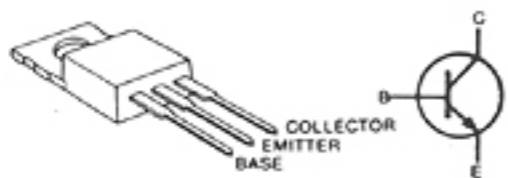

Q1

2SC3133

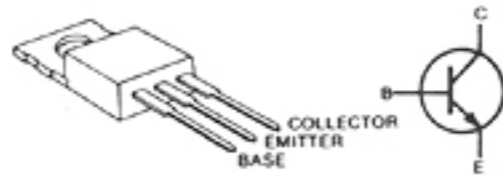

Q2, Q3

2SC2904

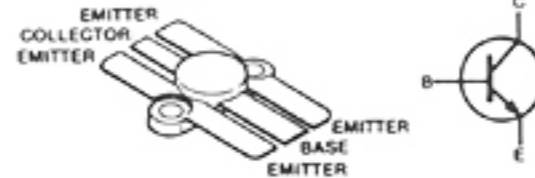

Q4, Q5

2SD1406

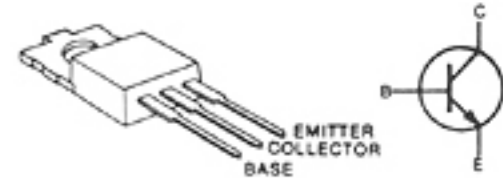

Q6

8-5 FILTER UNIT

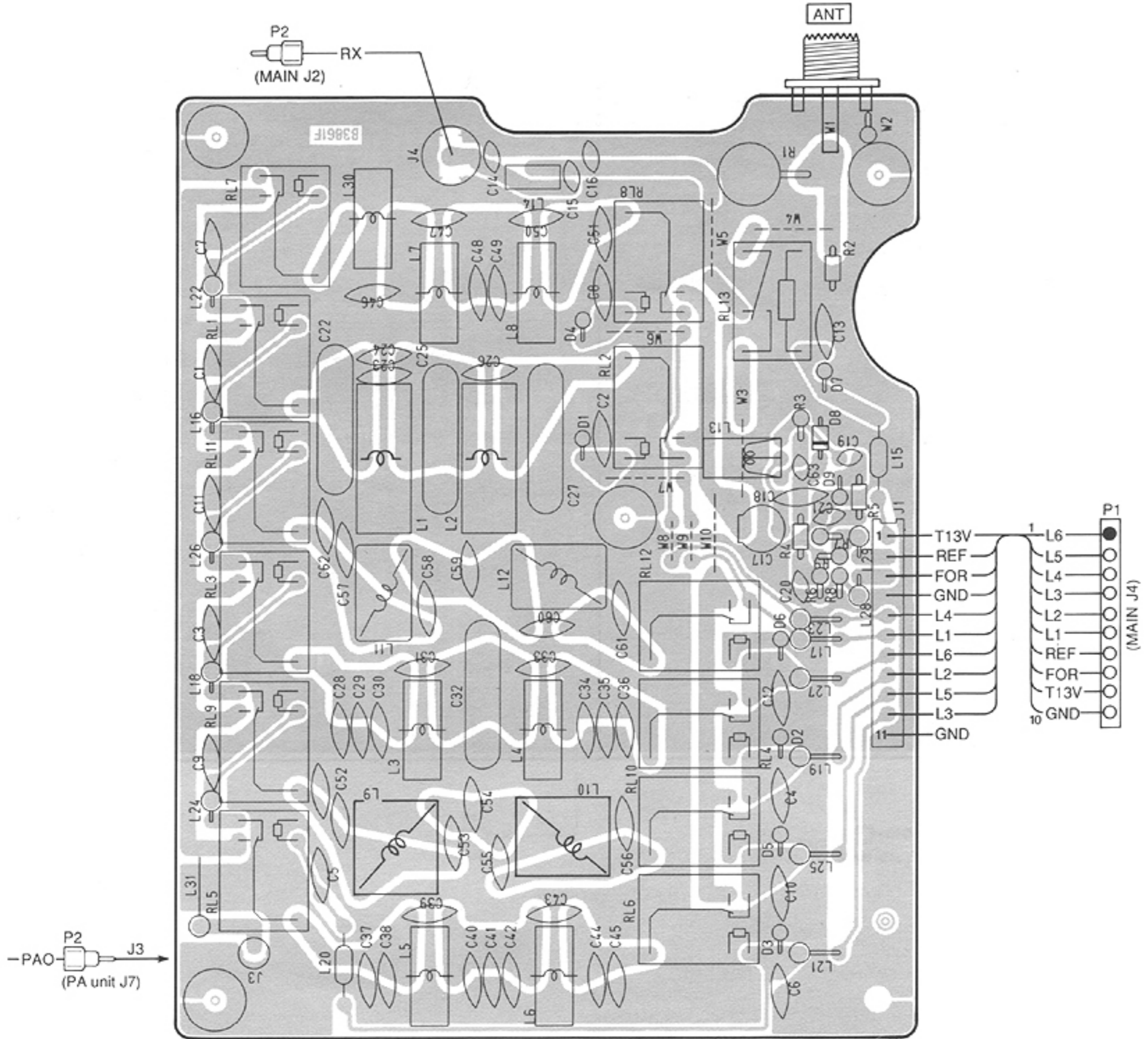

SECTION 9 BLOCK DIAGRAM

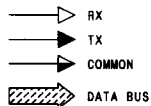
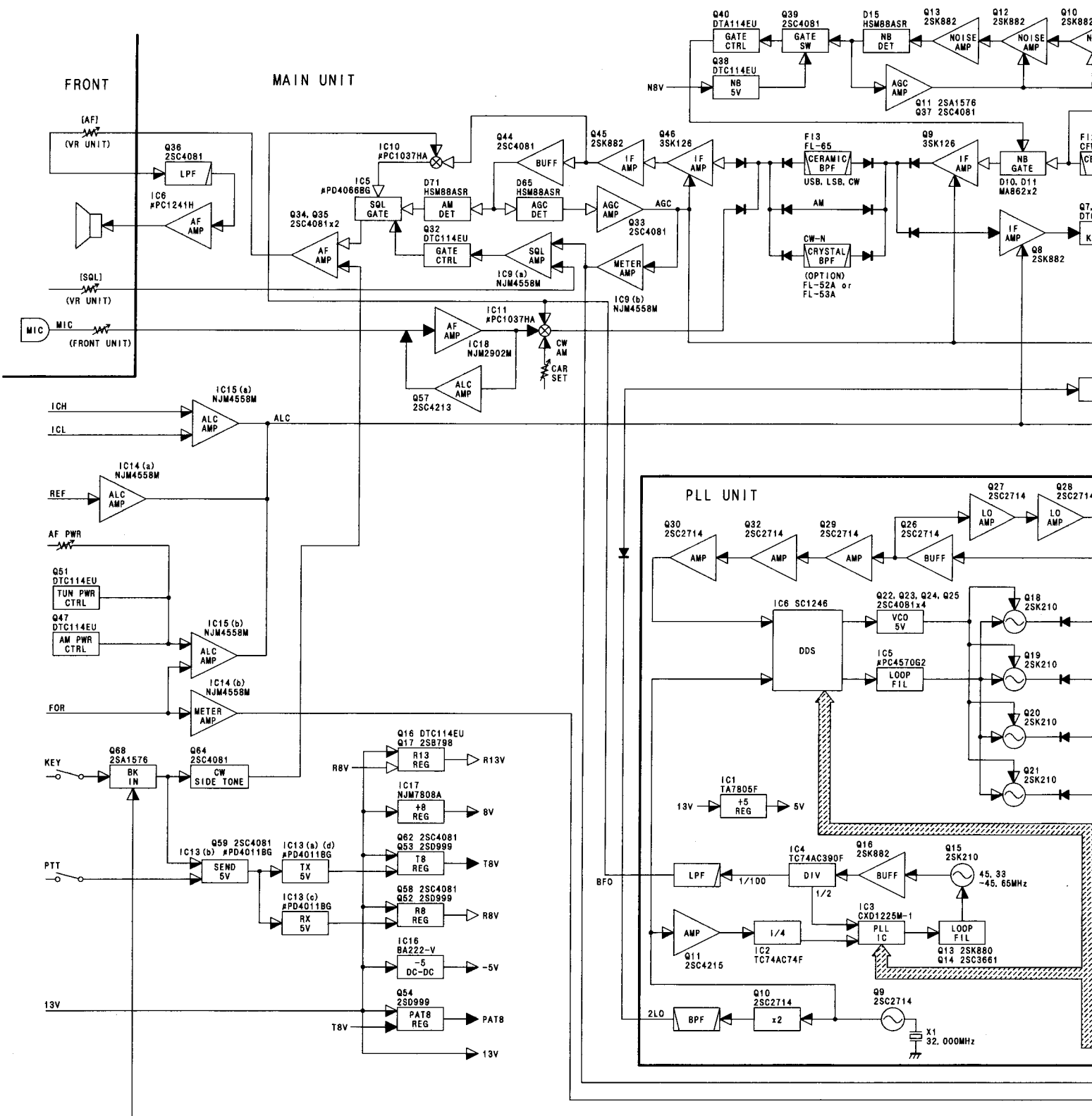

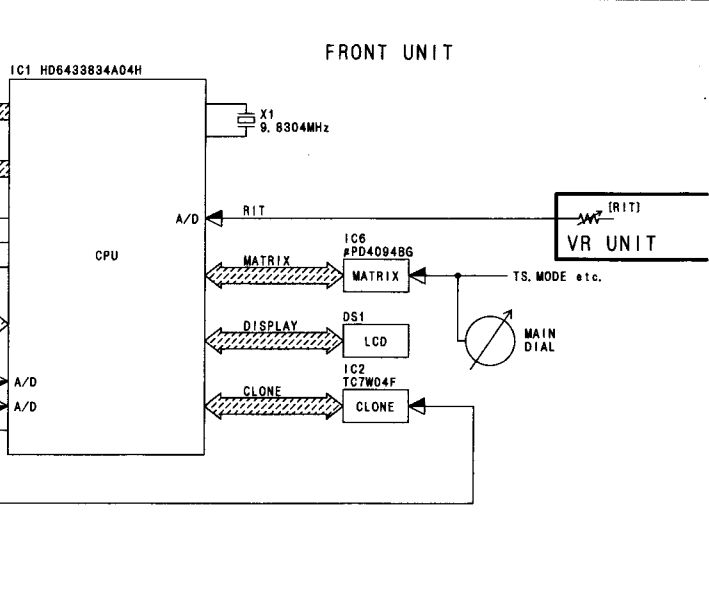
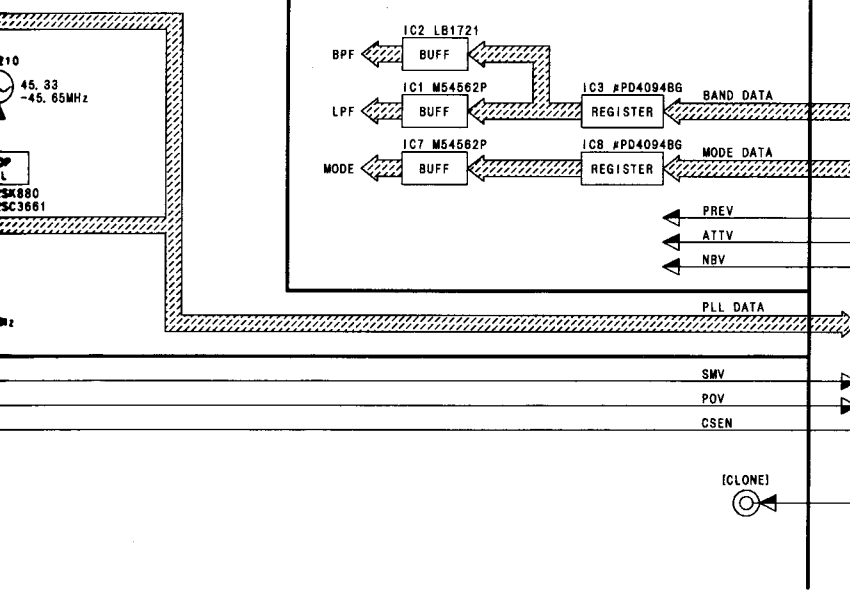
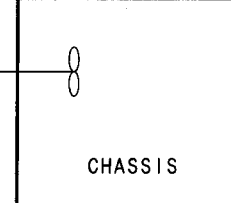
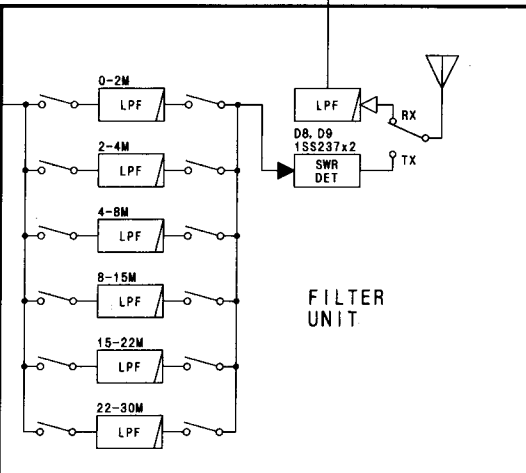
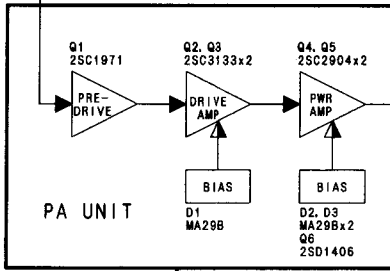
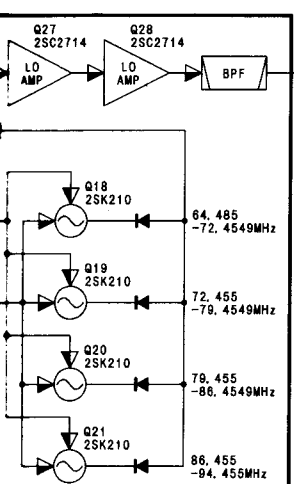
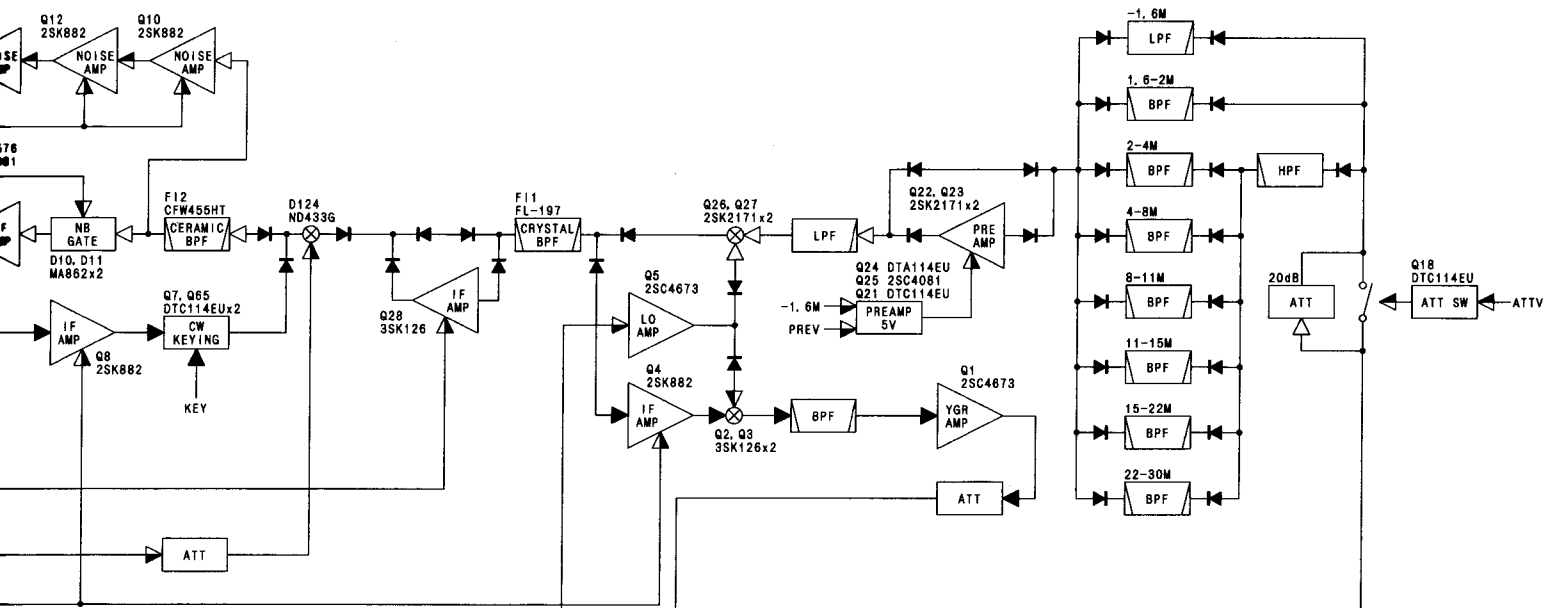

SECTION 10 VOLTAGE DIAGRAM

10-1 MAIN, PA AND FILTER UNITS

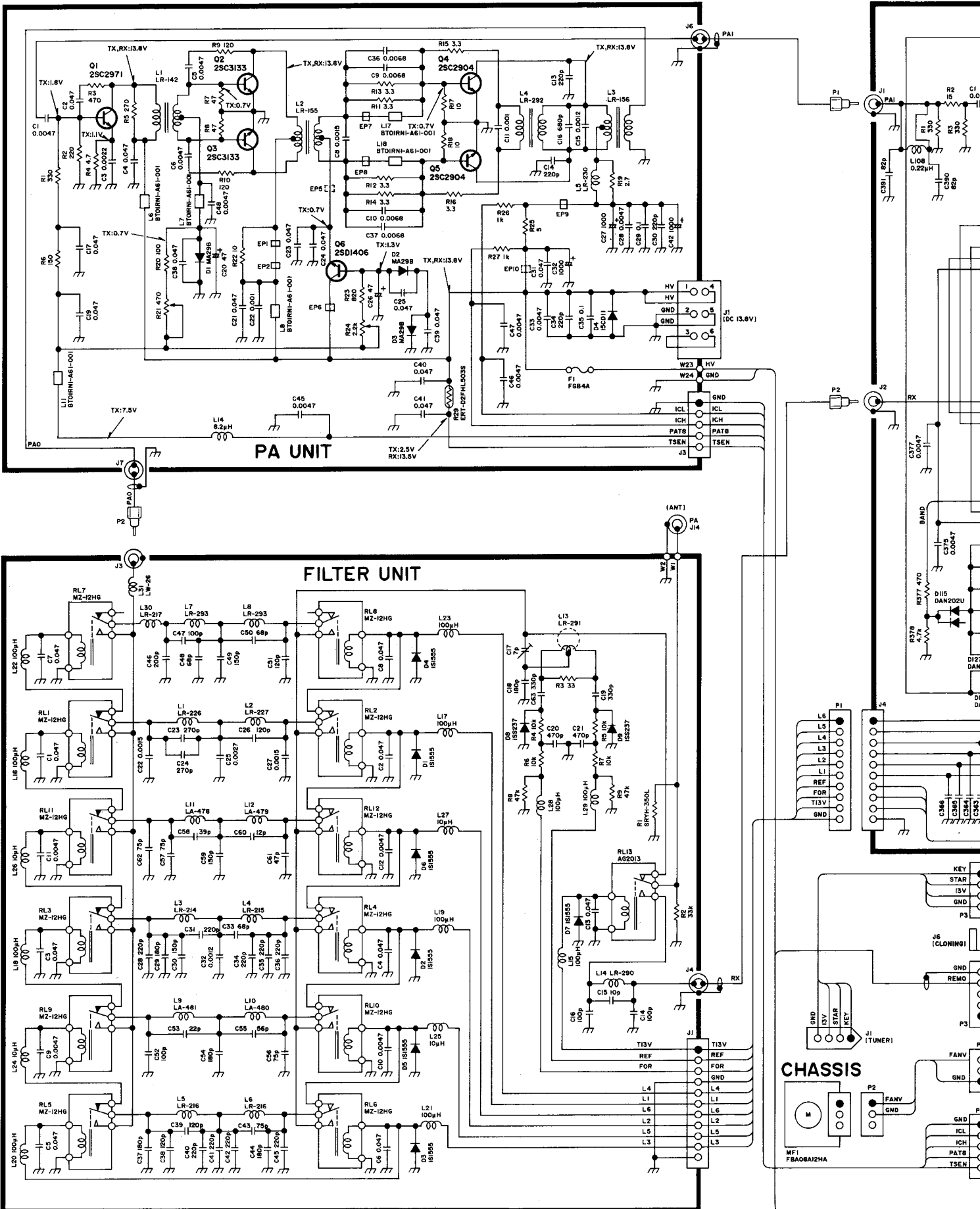

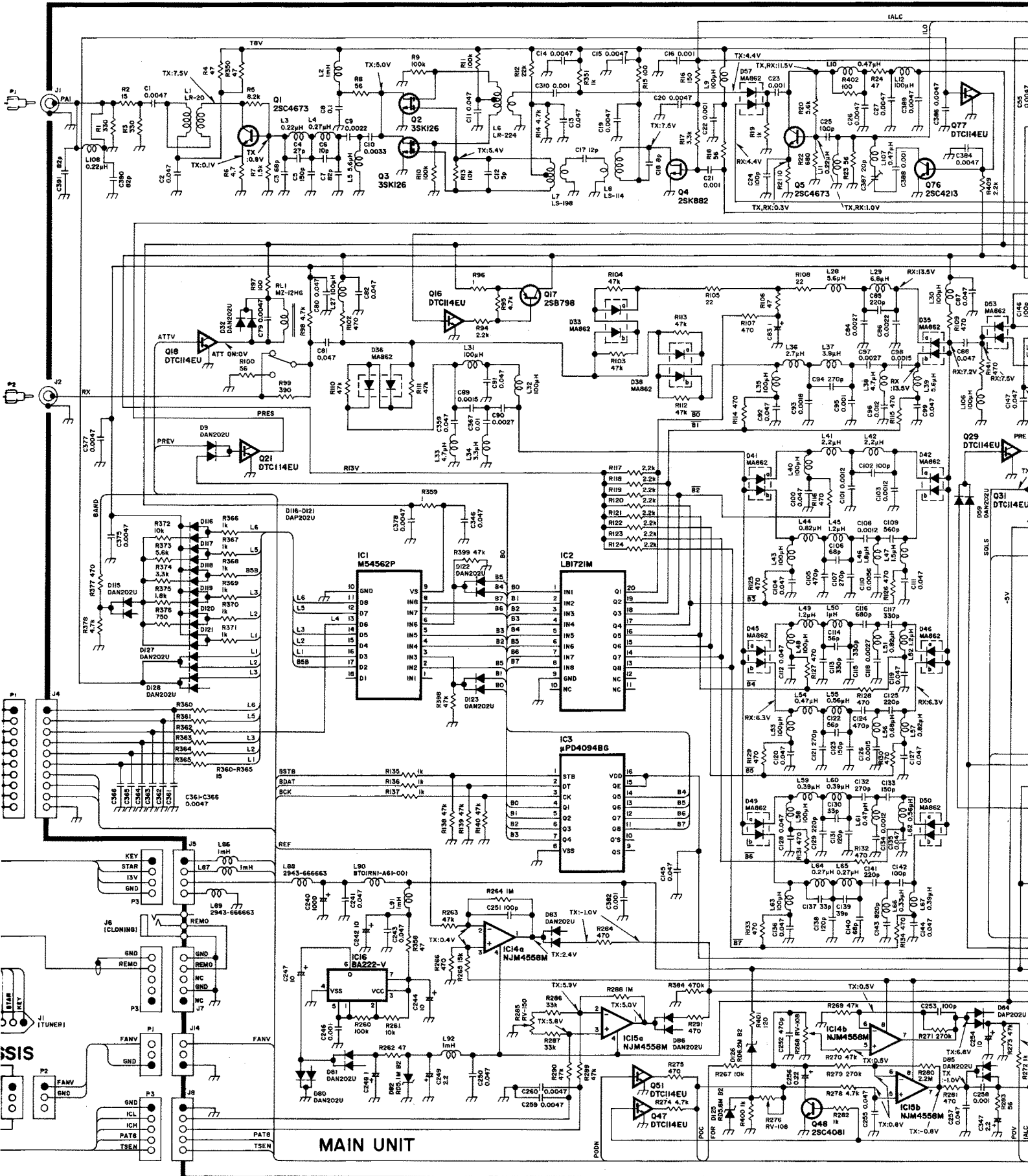

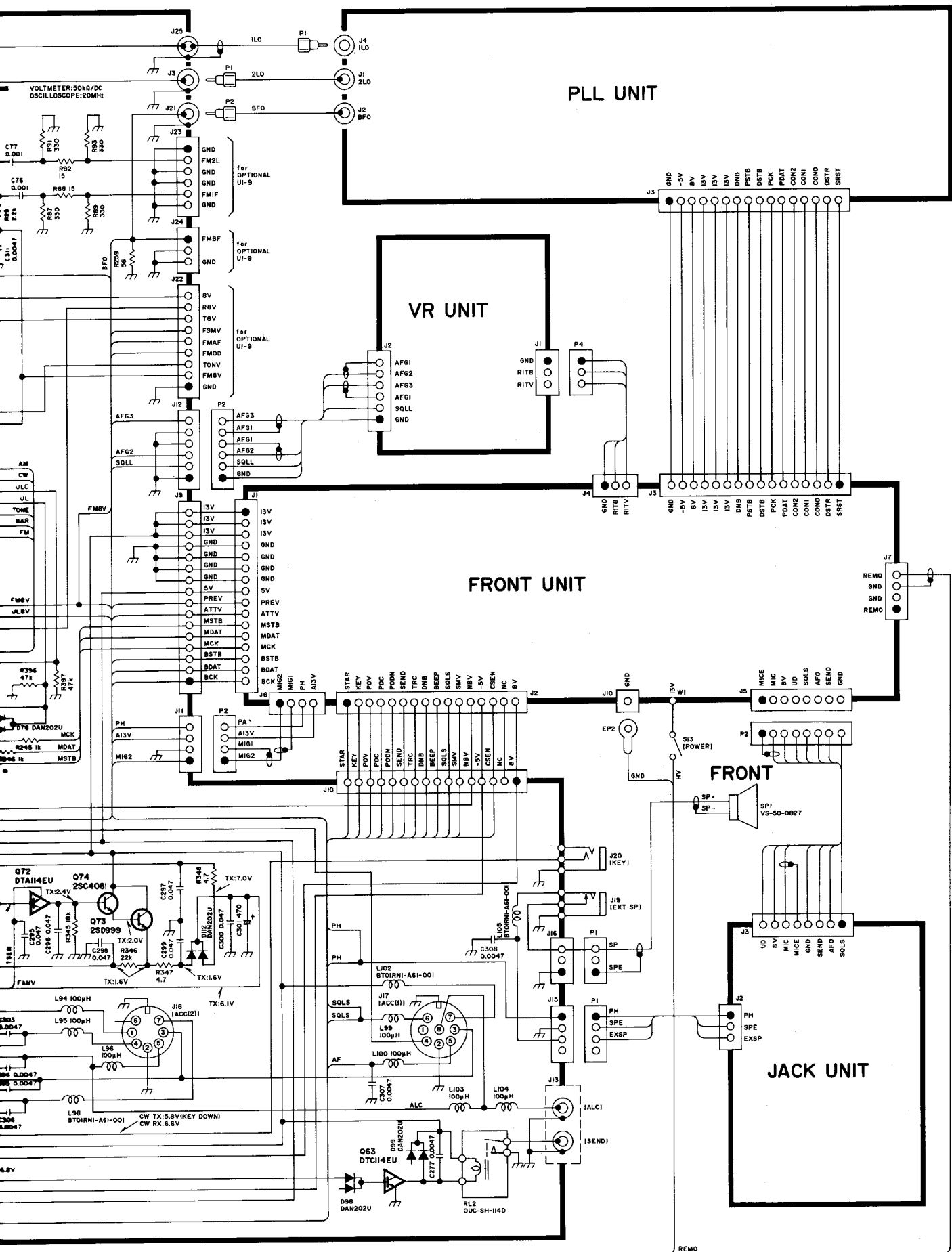

10-2 PLL AND FRONT UNITS

PLL UNIT

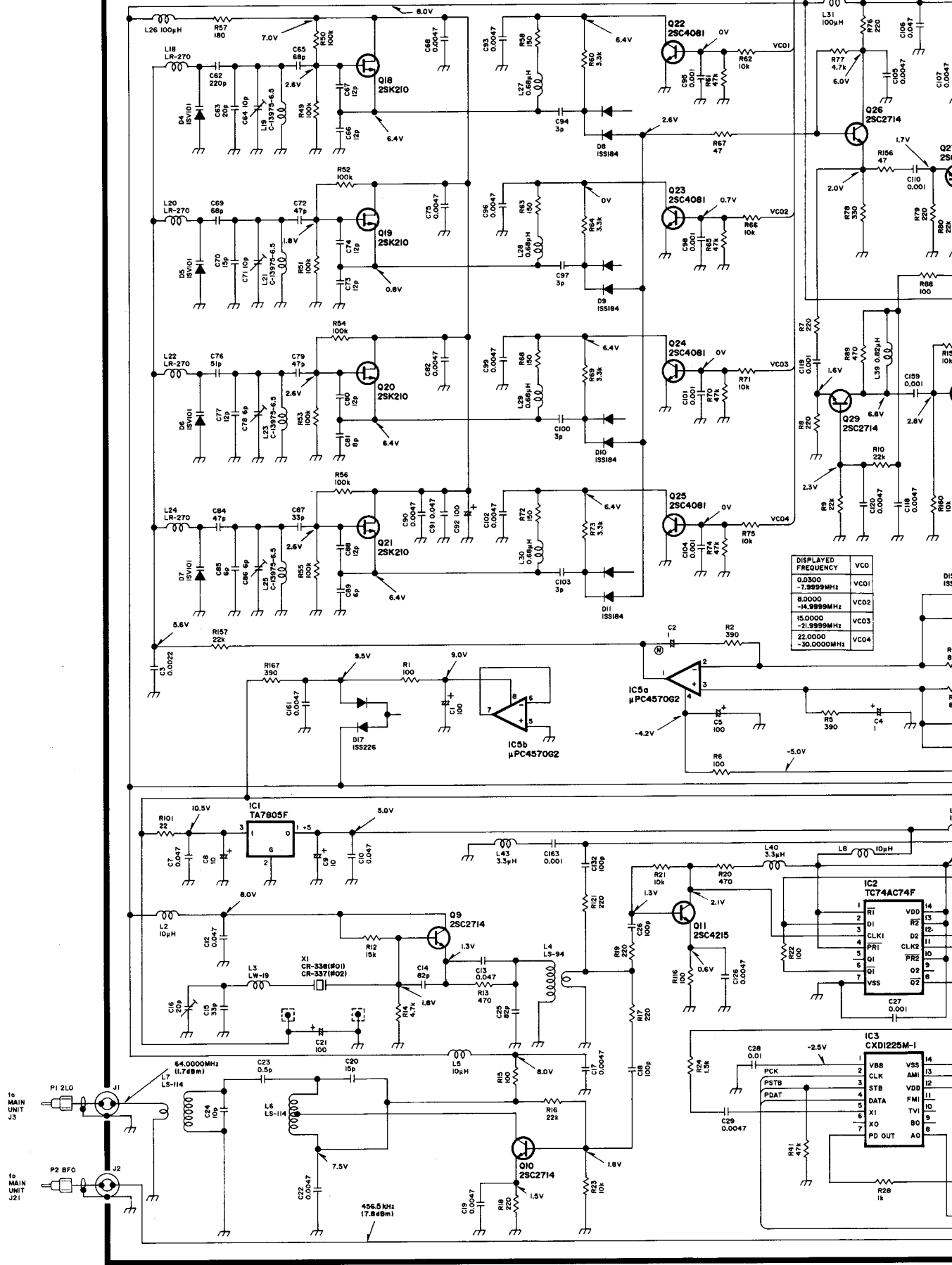

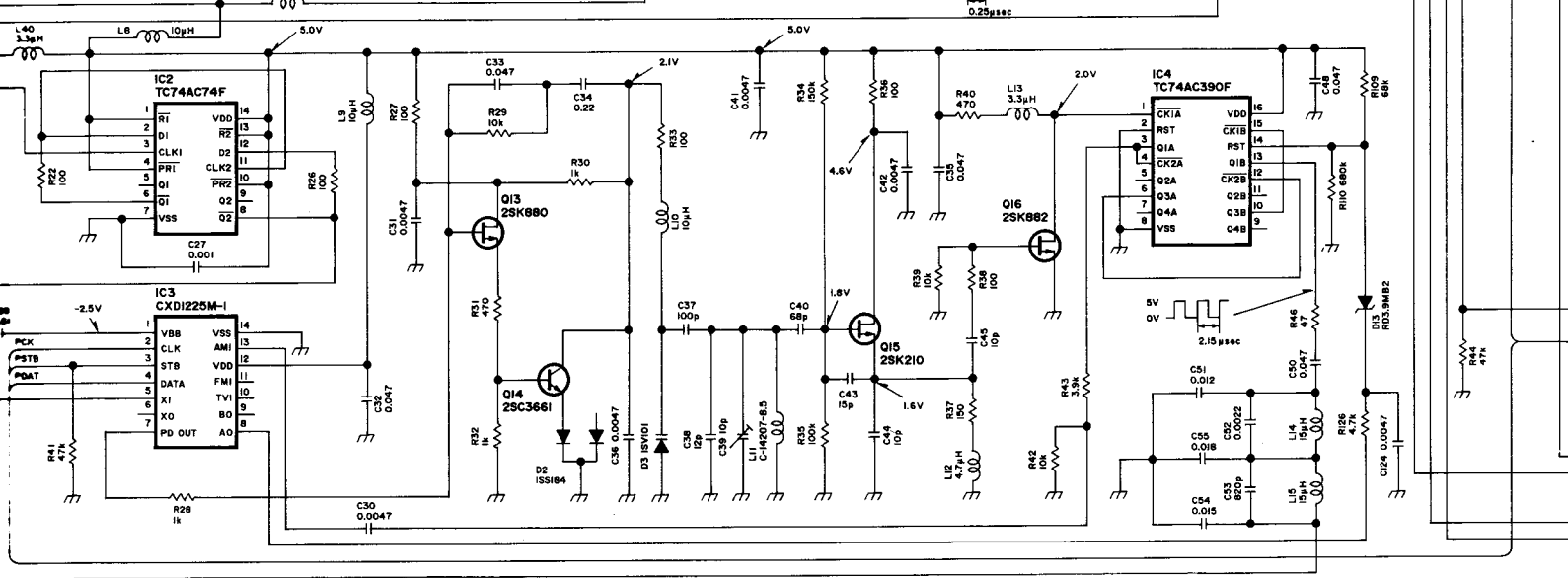
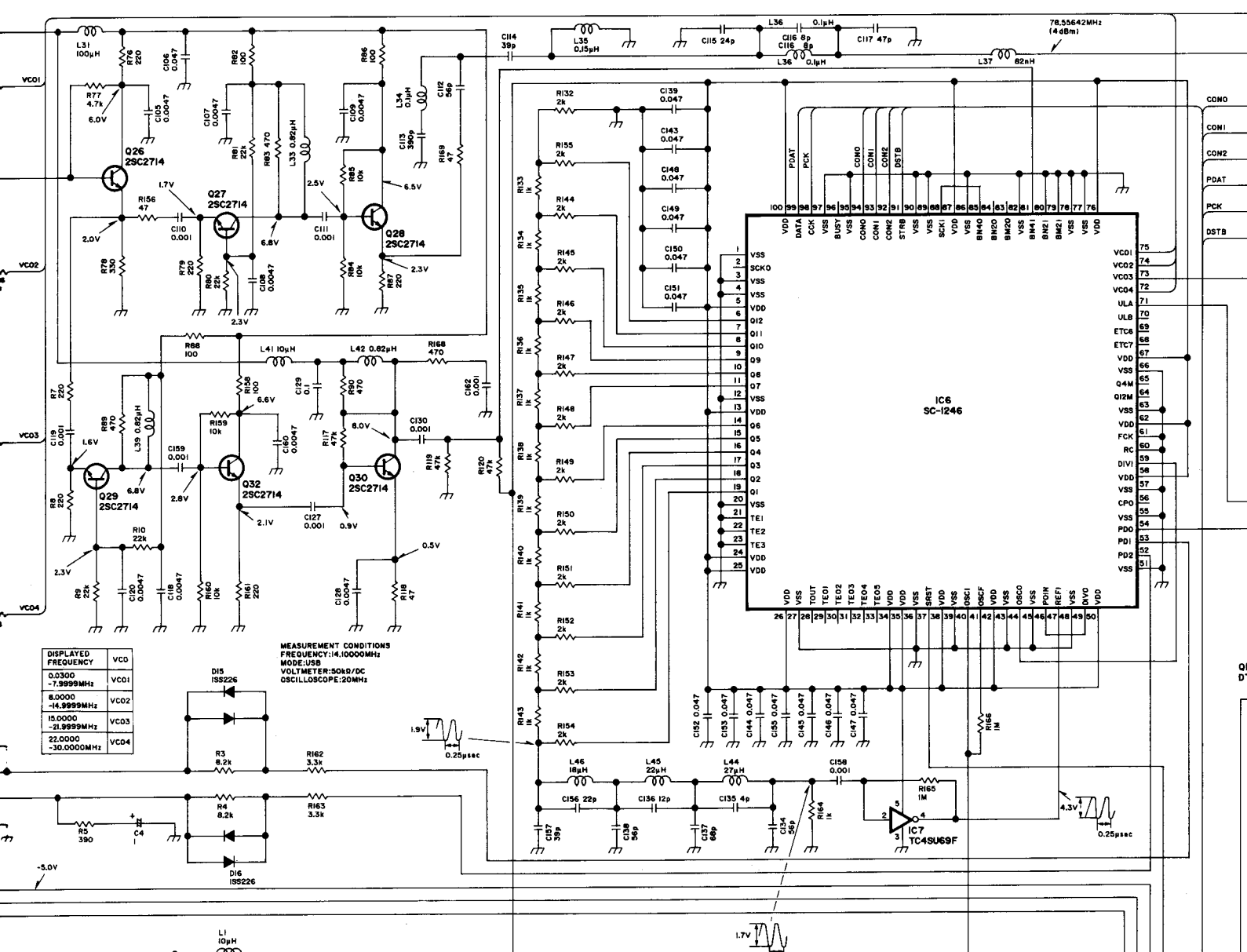

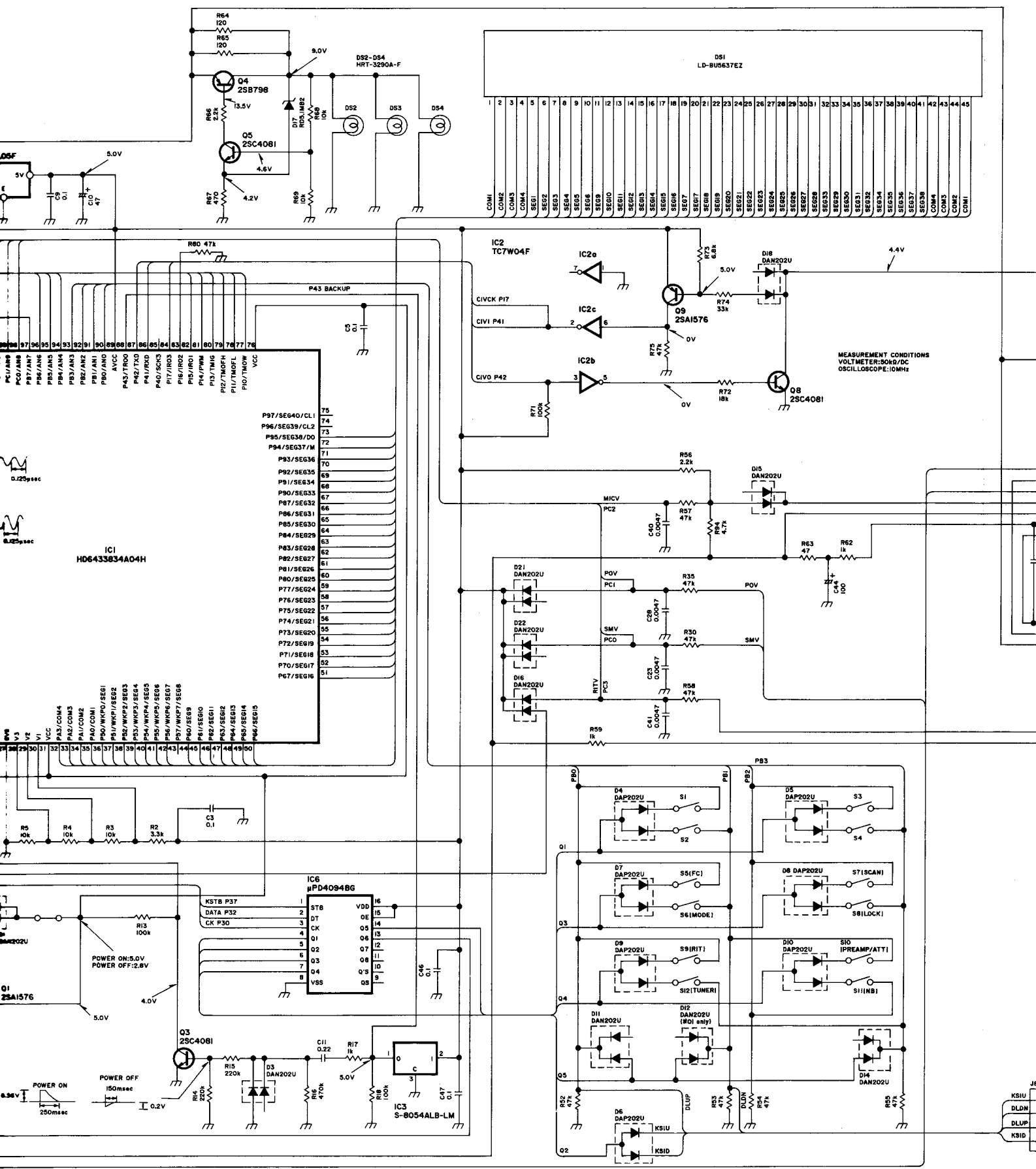

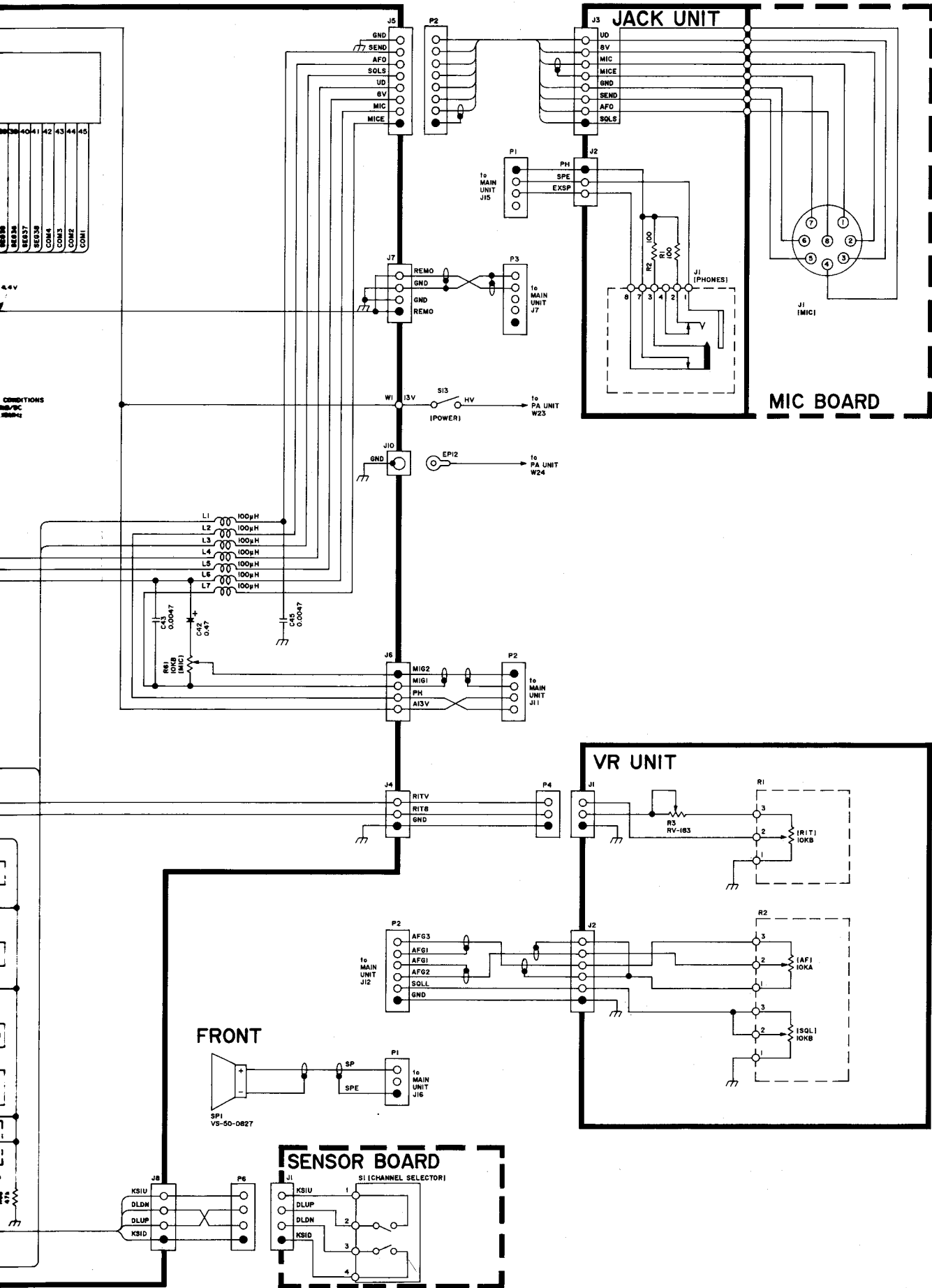

Icom Inc.

6-9-16, Kamihigashi, Hirano-ku, Osaka 547, Japan

Phone: 06 793 5302

Fax : 06 793 0013

Telex : 05277822 ICOMTR J

Icom America Inc.

<Corporate Headquarters>

2380 116th Avenue N.E., Bellevue, WA 98004, U.S.A.

Phone : (206) 454-8155

Fax : (206) 454-1509

Telex : 152210 ICOM AMER BVUE

<Customer Service>

Phone : (206) 454-7619

<Regional Customer Service Center>

18102 Sky Park South, Suite 52-B, Irvine, CA 92714, U.S.A.

Phone : (714) 852-8026

Fax : (714) 852-8716

Icom Canada

A Division of Icom America Inc.

3071 #5 Road, Unit 9, Richmond, B.C., V6X 2T4, Canada

Phone : (604) 273-7400

Fax : (604) 273-1900

Icom (Europe) GmbH

Communication Equipment

Himmelgeister Str. 100, 40225 Düsseldorf 1, Germany

Phone : 0211 346047

Fax : 0211 333639

Icom (Australia) Pty. Ltd.

A.C.N 006 092 575

7 Duke Street, Windsor, Victoria, 3181, Australia

Phone : 03 529 7582

Fax : 03 529 8485

Icom (UK) Ltd.

Unit 9, Sea St., Herne Bay, Kent, CT6 8LD, U.K.

Phone : 0227 741741

Fax : 0227 741742

Telex : 965179 ICOM G

Icom France S.a

Zac de la Plaine, Rue Brindejanc des Moulinais

BP 5804, 31505 Toulouse Cedex, France

Phone : 61. 36. 03. 03

Fax : 61. 34. 05. 91

Telex : 521515 ICOM FRA

Count on us!
